

Investigation Report

The Investigation Report was written in accordance with para 18 Law Relating to the Investigation into Accidents and Incidents Associated with the Operation of Civil Aircraft stating facts only.

Identification

Type of Occurrence:	Serious incident
Date:	9 February 2010
Location:	Cologne/Bonn Airport
Aircraft:	Transport aircraft
Manufacturer / Model:	Airbus / A 300 B4-203F
Injuries to Persons:	None
Damage:	Minor damage to aircraft
Other Damage:	None
State File Number:	BFU EX003-10

Factual Information

History of the Flight

At 2358 hrs¹ the cargo airplane, coming from Istanbul, Turkey, landed at Cologne/Bonn Airport at runway 32R. According to the statement of the crew the airplane had been decelerated normally after touchdown using thrust reverser and brakes. The crew also stated that during retraction of the thrust reverser at a speed of 80 kt the airplane had lurched slightly left. By actuating the control pedals the airplane was kept on track. After the thrust reverser had been retracted the REV and the REV-UNLIK indication for the thrust reverser of the right engine remained green and yellow, respectively.

After the airplane had been parked at the stand the ground crew informed the flight crew that the left fan reverser translating cowl of the right engine was missing. At 0014 hrs the flight crew informed the tower accordingly.

At 0002 hrs a cargo airplane, a Boeing B767, landing immediately afterwards had rolled through the debris of the fan reverser translating cowl and been damaged.

Personnel Information

The 62-year-old Pilot in Command (PIC) held an Air Transport Pilot's License (ATPL) issued by the Turkish aeronautical authority in accordance with ICAO and JAR-FCL with the commensurate class and type ratings. The pilot held a class 1 medical certificate. He had a total flying experience of 20,650 hours; 8,500 hours of which on Airbus A300.

The 41-year-old co-pilot held a Commercial Pilot's Licence (CPL(A)) issued by the Turkish aeronautical authority in accordance with ICAO and JAR-FCL with the commensurate class and type ratings.

Aircraft Information

The Airbus A 300 B4-203 F is a low-wing cargo aircraft in all-metal construction with a retractable landing gear in nose wheel configuration. The maximum take-off mass was 165,000 kg. The airplane with the serial number 123 was manufactured in 1980.

¹ All times local, unless otherwise stated.

At the time of the occurrence it had a total operating time of 50,734 hours and 26,566 total airframe landings.

The airplane was equipped with two General Electric CF6-50-C2 jet engines. The total operating time of engine No. 1 (left), serial number 530213, was 54,195 hours and 12,567 cycles; engine No. 2 (right), serial number 528204, was 30,625 hours and 15,006 cycles.

According to the release to service, the last maintenance check (A41) was performed on 28 January 2010.

Meteorological Information

It was night, it snowed, and wind direction and velocity was 320°/7 kt. Ground visibility was 6,000 m.

Radio Communications

Radio transmissions with the air traffic control unit were recorded and made available to the BFU as transcript. It was used to reconstruct the chronological course of events.

Aerodrome Information

Cologne/Bonn Airport has three runways. The runway used by the aircraft involved had an asphalt covering and the direction 14L/32R, was 3,815 m long and 60 m wide. The parallel runway with the direction 14R/32L was 1,863 m long and 45 m wide and was covered with concrete and asphalt. The third runway had a concrete covering, the direction 06/24, and was 2,459 m long and 45 m wide.

Flight Recorder

The airplane was equipped with a Sundstrand Data Contr Flight Data Recorder (FDR), S/N 3303; and a Sundstrand, Mod. AV557C, S/N 10087 Cockpit Voice Recorder (CVR). The recorded data were available to the BFU for evaluation. They did not reveal any information regarding the course of events.

Wreckage and Impact Information

Debris of the fan reverser translating cowl was lying on runway 32R in the area between taxiway h and the intersection of runway 06/24. Before the BFU arrived the debris was removed by members of the airport fire brigade and employees of the airport.

The left fan reverser translating cowl of the right engine was missing (Appendix Image 1). The type plate of the fan reverser translating cowl showed the following information: Model-No CF6-50 TR-CF-6-F3; Assy Ident No 9007M60G46; Serial No MBC 00280; MFR Ident No 38597. The upper and the centre ball screw were in the position of a retracted thrust reverser cowl. The connecting tube including bracket were present (Appendix Image 2). The lower ball screw was extended by 22 cm (between partition plate and transport nut). The connecting tube to the cowling was torn off (Appendix Image 3). The cascades were abraded in the area of the bracket of the upper and centre ball screw. The partition plate between drive and thrust reverser cascades were ground out in the area of the lower shaft feed through (Appendix Image 3). The toggles for the blocker doors were fractured. Together with the fan reverser translating cowl the blocker doors had fallen off.

A dent was visible at the aft left part of the cowling of the inner flap drive of the right wing (facing the fuselage). In this area scratches were found on the lower surface of the flap.

In the lower area of the fan reverser translating cowl the rivet holes between inner and outer cowling in the vicinity of the lower carriage were heavily ground out. The cowling had been torn off the rail. The carriage and part of the structure were still stuck in the rail on the engine (Appendix Image 4).

The air intake of the right engine of the B767, who landed after the A300, was dented (Appendix Image 5), the wheel on the positions 4 and 8 on the right main landing gear were damaged. The air intake and wheel No 4 were replaced.

Fire

There was no fire.

Additional Information

In the past thrust reverser cowlings or parts thereof had separated from airplanes. In August 2009 the thrust reverser manufacturer had published a fan reverser service

memorandum (Appendix). In this memorandum the manufacturer recommends that airplane operators should conduct additional checks on the thrust reversers in order to prevent age-related malfunctions und therefore reduce resulting damages and failures. Depending on the extent, the additional checks should be conducted during the first or second C-check, respectively.

Investigator in charge: Nehmsch

Assistance: Berndt

Hempelmann

Ritschel

Karge

Field investigation: Nehmsch

Berndt

Braunschweig 28 February 2018

Appendices



Image 1: Left side of the right engine (facing the fuselage)

Photo: BFU



Image 2: Upper, centre, and lower ball screw shaft

Photo: BFU



Image 3: Extended and fractured ball screw shaft

Photo: BFU



Image 4: Remnant of the torn off fan reverser translating cowl stuck in the rail

Photo: BFU



Image 5: Indented air intake of the right engine of a Boeing B767

Photo: BFU



Middle River Aircraft Systems

Fan Reverser Service Memorandum
--

REVERSER MODELS: CF6-6/CF6-50
MAINTENANCE NO: 06
DATE: 5 AUGUST 2009
SUBJECT: TRANSLATING COWL PERIODIC
STRUCTURAL INSPECTIONS

PURPOSE

The purpose of this Fan Reverser Service Memorandum (FRSM) is to provide operators with instructions to periodically perform inspections of the translating cowl. This will reduce the possibility of significant degradation of translating cowls that could lead to liberation of the translating cowl or pieces of the translating cowl during flight or reverse thrust operation.

GE Commercial Engine Service Memoranda (CESM) have always recommended general structural inspections of the Thrust Reverser at each C-Check. MRAS is issuing this FRSM as a supplement to the current maintenance documents to heighten the awareness of critical translating cowl inspections that can prevent parts departing the aircraft. MRAS recommends that operators incorporate FRSM No. 6 inspections into existing maintenance plans.

Periodic inspection per this FRSM will also help prevent the burden of unscheduled removals of translating cowls due to unserviceable conditions.

DESCRIPTION OF THE PROBLEM

Aging metal translating cowls are more susceptible to corrosion and adhesive disbonds over time than composite translating cowls. The effects of wear, bumper and deactivation lockplate contact, Thrust Reverser Actuation System degradation and rigging issues can all lead to high end of stroke impacts and can damage aging structure. Cracking and disbonding has been reported on translating cowls with more than 15,000 flight cycles since new. The structural health of translating cowls depends on the level of prior inspections, early repair of minor items, and preventative maintenance performed during service life. Translating cowls that have had complete shop visits and are within the warranty period of a recent overhaul should not require the inspections in this FRSM.

Middle River Aircraft Systems**Fan Reverser
Service Memorandum**HISTORY

MRAS has investigated numerous field events involving CF6-6 and CF6-50 translating cowls. An increasing number of reports have been received of translating cowls having liberated, or nearly liberated, significant portions of structure due to corrosion or other structural issues. Two examples follow.

On 10 February 2007, a CF6-50-powered A300B airplane experienced liberation of the left-hand translating cowl forward outer bondment during flight. This aircraft had been in service for twenty-seven years. Investigation revealed that the translating cowl had never undergone a shop overhaul or re-skin repairs to major bondments. Several cosmetic repairs had been accomplished.

On 30 May 2007, a CF6-6-powered MD-10-10 airplane experienced liberation of the left-hand translating cowl on landing. This aircraft had been in service for more than twenty-eight years. Investigation revealed major corrosion, substandard bond repairs and superficial maintenance actions.

RECOMMENDATIONS

MRAS recommends accomplishment of the on-wing translating cowl inspections contained in this FRSM at scheduled C-Checks (or approximately every 18 months).

MRAS recommends the removal of the translating cowl from the aircraft at every second scheduled C-Check and accomplishment of the off-wing inspections contained in this FRSM (or approximately every 36 months). Preventative off-wing inspections are necessary in order to fully gain access to the inside of the translating cowl cavity for complete inspection.

For airlines uncertain of the past shop visit history of their translating cowls, MRAS recommends performing the off-wing translating cowl inspections contained in this FRSM at the next C-Check of each airplane to establish a fleet baseline.

Middle River Aircraft Systems**Fan Reverser
Service Memorandum**TRANSLATING COWL ON-WING INSPECTIONS

MRAS recommends that the following procedures be accomplished at every C-Check or approximately every 18 months unless the translating cowls have been removed for the off-wing inspections detailed in the next FRSM section entitled TRANSLATING COWL OFF-WING INSPECTIONS. Manually deploy the translating cowl in order to provide inspection access to the cavity of the translating cowl. If damage or disbonds are found outside of the Engine Shop Manual limits, contact MRAS Technical Support (technical_support@mras-usa.com) for disposition. During inspections, pay close attention to previous repairs as they are indicators of past problems.

- 1) Refer to Figure 3. Inspect the three actuator clevis areas marked "AREA A" and the two close-out casting areas marked "AREA B" for the following:
 - (a) Visually inspect the outer skin for any signs of cracking or any indication of loose or missing rivets at fastener locations.
 - (b) Visually inspect for a cracked, broken or dislodged lower actuator support assembly. Refer to Figure 5 for an example.
 - (c) Visually inspect for cracked, broken or dislodged upper actuator clevis and mid actuator clevis. Refer to Figure 4 for examples.
- 2) Refer to Figure 2, Sheet 1. Inspect the upper and lower cowl guides and adjacent structure for serviceability, wear, missing or torn wear strips, and looseness per CF6-6 Engine Manual GEK 9266 Section 78-32-01 or CF6-50 Engine Manual GEK 50481 Section 78-32-01.
- 3) Refer to Figure 2, Sheet 1. Inspect the translating cowl bumpers located on the forward edge of the cowl for wear. Inspect the thrust reverser fixed structure adjacent to the translating cowl bumpers and deactivation lockplates for any indication of contact or damage. If contact or damage has occurred, adjust and shim the bumpers or deactivation plates per CF6-6 Engine Manual GEK 9266 Section 78-32-01 or CF6-50 Engine Manual GEK 50481 Section 78-32-01. Refer to Figure 6 for translating cowl bumper and lockplate to fixed structure clearances.

Middle River Aircraft Systems**Fan Reverser
Service Memorandum**TRANSLATING COWL ON-WING INSPECTIONS (Continued)

- 4) Perform a tap test of the translating cowl outer bondment "areas of concern" shown in Figure 3 to inspect for disbonds.
- (a) Actuator Clevis "Area A" (three areas per translating cowl)
- Maximum Serviceable Limits: Refer to CF6-6 Engine Manual GEK 9266 Section 78-32-01 or CF6-50 Engine Manual GEK 50481 Section 78-32-01.
 - Maximum Repairable Limits: Refer to CF6-6 Engine Manual GEK 9266 Section 78-32-01 or CF6-50 Engine Manual GEK 50481 Section 78-32-01.
 - Repair Method: Repair 004 or Repair 019 of CF6-6 Engine Manual GEK 9266 Section 78-32-01; Repair 004 or Repair 020 of CF6-50 Engine Manual GEK 50481 Section 78-32-01
- (b) Top and Bottom Close-out "Area B" (two areas per translating cowl)
- Maximum Serviceable Limits: Refer to CF6-6 Engine Manual GEK 9266 Section 78-32-01 or CF6-50 Engine Manual GEK 50481 Section 78-32-01.
 - Maximum Repairable Limits: Refer to CF6-6 Engine Manual GEK 9266 Section 78-32-01 or CF6-50 Engine Manual GEK 50481 Section 78-32-01.
 - Repair Method: Repair 004 or Repair 019 of CF6-6 Engine Manual GEK 9266 Section 78-32-01; Repair 004 or Repair 020 of CF6-50 Engine Manual GEK 50481 Section 78-32-01

Middle River Aircraft Systems**Fan Reverser
Service Memorandum**TRANSLATING COWL ON-WING INSPECTIONS (Continued)

4. (c) Visually inspect the remaining portion of the outer bondment for any signs of obvious damage, corrosion, or disbonding. Pay particular attention to the circumferential split line where the forward and aft outer bondments are spliced together. Tap test or perform a more detailed inspection of those areas with obvious visual damage.
- Maximum Serviceable Limits: Refer to CF6-6 Engine Manual GEK 9266 Section 78-32-01 or CF6-50 Engine Manual GEK 50481 Section 78-32-01.
 - Maximum Repairable Limits: Refer to CF6-6 Engine Manual GEK 9266 Section 78-32-01 or CF6-50 Engine Manual GEK 50481 Section 78-32-01.
 - Repair Method: Repair 003 or Repair 004 of CF6-6 Engine Manual GEK 9266 Section 78-32-01; Repair 003 or Repair 004 of CF6-50 Engine Manual GEK 50481 Section 78-32-01

Middle River Aircraft Systems**Fan Reverser
Service Memorandum**TRANSLATING COWL OFF-WING INSPECTIONS

MRAS recommends that the following procedures be accomplished at every second C-Check (or approximately every 36 months). Removing the translating cowl from the thrust reverser will allow for better access to visually inspect the inner cavity of the translating cowl, the actuator clevis pins and the adjacent clevis attachments and upper and lower tee-hinges. If damage or disbonds are found outside of the Engine Shop Manual limits, contact MRAS Technical Support (technical_support@mras-usa.com) for disposition. During inspections, pay close attention to previous repairs as they are indicators of past problems.

- 1) Remove the translating cowl from the fan reverser per the applicable Aircraft Maintenance Manual (AMM).
- 2) Using three approximately 4 inch X 4 inch X 4 inch (100 mm X 100 mm X 100 mm) blocks of wood (or equivalent), place the translating cowl on its leading edge with the blocks located at the upper end, middle and lower end of the translating cowl.
- 3) Refer to Figure 1, Sheets 1 and 2. Remove the three aft and the three forward sound panels from the inner surface of the translating cowl. Retain the attaching hardware. Inspect each sound panel per CF6-6 Engine Manual GEK 9266 Section 78-32-02 or CF6-50 Engine Manual GEK 50481 Section 78-32-02.
- 4) With the sound panels removed, visually inspect the underlying structures of the Translating Cowl for cracks, disbonds and corrosion per CF6-6 Engine Manual GEK 9266 Section 78-32-01 or CF6-50 Engine Manual GEK 50481 Section 78-32-01.
- 5) Reposition the translating cowl on a suitable holding device so that the inner (concave) surface is facing up.
- 6) Refer to Figure 2, Sheets 1 and 2. Inspect "Area 1" of the translating cowl.
 - (a) Visually inspect the inboard surface of the forward closeout frame that joins the forward and aft outer bondments. Visually inspect the frame from the upper end to the lower end for cracks, disbonds and corrosion per CF6-6 Engine Manual GEK 9266 Section 78-32-01 or CF6-50 Engine Manual GEK 50481 Section 78-32-01.
 - (b) Cracks, each having a maximum allowable length of 11 inches (279 mm), can be repaired at the upper and lower edges of the translating cowl forward closeout. Repair cracks per Repair 029 of CF6-6 Engine Manual GEK 9266 Section 78-32-01 or per Repair 031 of CF6-50 Engine Manual GEK 50481 Section 78-32-01.

Middle River Aircraft Systems**Fan Reverser
Service Memorandum**TRANSLATING COWL OFF-WING INSPECTIONS (Continued)

- 7) Refer to Figure 2, Sheets 1 and 3. Inspect "Area 2" of the translating cowl.
- (a) Visually inspect the inboard surfaces of the U-channel that joins the inner and outer bondments. Inspect the channel from the upper end to the lower end for cracks, disbonds and corrosion per CF6-6 Engine Manual GEK 9266 Section 78-32-01 or CF6-50 Engine Manual GEK 50481 Section 78-32-01. Tap check any area where a disbond is suspected.
 - (b) Cracks, each having a maximum allowable length of 25 inches (635 mm), can be reinforced by installing a locally manufactured doubler per Repair 027 of CF6-6 Engine Manual GEK 9266 Section 78-32-01 or per Repair 027 of CF6-50 Engine Manual GEK 50481 Section 78-32-01.
- 8) Refer to Figure 3. Inspect the three actuator clevis areas marked "AREA A" and the two close-out casting areas marked "AREA B" for the following:
- (a) Visually inspect the outer skin for any signs of cracking or any indication of loose or missing rivets at fastener locations.
 - (b) Visually inspect for a cracked, broken or dislodged lower actuator support assembly. Refer to Figure 5 for an example. Repair damage per Repair 006 of CF6-6 Engine Manual GEK 9266 Section 78-32-01 or Repair 009 of CF6-50 Engine Manual GEK 50481 Section 78-32-01.
 - (c) Visually inspect for cracked, broken or dislodged upper actuator clevis and mid actuator clevis. Refer to Figure 4 for examples. Repair per Repair 007 of CF6-6 Engine Manual GEK 9266 Section 78-32-01 or Repair 010 of CF6-50 Engine Manual GEK 50481 Section 78-32-01.
- 9) Using three approximately 4 inch X 4 inch X 4 inch (100 mm X 100 mm X 100 mm) blocks of wood (or equivalent), place the translating cowl on its leading edge with the blocks located at the upper end, middle and lower end of the translating cowl.

Middle River Aircraft Systems**Fan Reverser
Service Memorandum**TRANSLATING COWL OFF-WING INSPECTIONS (Continued)

10) Perform a tap test of the translating cowl outer bondment "areas of concern" shown in Figure 3 to inspect for disbonds.

(a) Actuator Clevis "Area A" (three areas per translating cowl)

- Maximum Serviceable Limits: Refer to CF6-6 Engine Manual GEK 9266 Section 78-32-01 or CF6-50 Engine Manual GEK 50481 Section 78-32-01.
- Maximum Repairable Limits: Refer to CF6-6 Engine Manual GEK 9266 Section 78-32-01 or CF6-50 Engine Manual GEK 50481 Section 78-32-01.
- Repair Method: Repair 004 or Repair 019 of CF6-6 Engine Manual GEK 9266 Section 78-32-01 or Repair 004 or Repair 020 of CF6-50 Engine Manual GEK 50481 Section 78-32-01

(b) Top and Bottom Close-out "Area B" (two areas per translating cowl)

- Maximum Serviceable Limits: Refer to CF6-6 Engine Manual GEK 9266 Section 78-32-01 or CF6-50 Engine Manual GEK 50481 Section 78-32-01.
- Maximum Repairable Limits: Refer to CF6-6 Engine Manual GEK 9266 Section 78-32-01 or CF6-50 Engine Manual GEK 50481 Section 78-32-01.
- Repair Method: Repair 004 or Repair 019 of CF6-6 Engine Manual GEK 9266 Section 78-32-01 or Repair 004 or Repair 020 of CF6-50 Engine Manual GEK 50481 Section 78-32-01

Middle River Aircraft Systems**Fan Reverser
Service Memorandum**TRANSLATING COWL OFF-WING INSPECTIONS (Continued)

10. (c) Visually inspect the remaining portion of the outer bondment for any signs of obvious damage, corrosion, or disbonding. Pay particular attention to the circumferential split line where the forward and aft outer bondments are spliced together. Tap test or perform a more detailed inspection of those areas with obvious visual damage.
- Maximum Serviceable Limits: Refer to CF6-6 Engine Manual GEK 9266 Section 78-32-01 or CF6-50 Engine Manual GEK 50481 Section 78-32-01.
 - Maximum Repairable Limits: Refer to CF6-6 Engine Manual GEK 9266 Section 78-32-01 or CF6-50 Engine Manual GEK 50481 Section 78-32-01.
 - Repair Method: Repair 003 or Repair 004 of CF6-6 Engine Manual GEK 9266 Section 78-32-01 or Repair 003 or Repair 004 of CF6-50 Engine Manual GEK 50481 Section 78-32-01
- 11) Refer to Figure 2, Sheet 1. Inspect the upper and lower cowl guides and adjacent structure for serviceability, wear, missing or torn wear strips, and looseness per CF6-6 Engine Manual GEK 9266 Section 78-32-01 or CF6-50 Engine Manual GEK 50481 Section 78-32-01.
- 12) Refer to Figure 2, Sheet 1. Inspect the forward translating cowl bumpers for wear per CF6-6 Engine Manual GEK 9266 Section 78-32-01 or CF6-50 Engine Manual GEK 50481 Section 78-32-01.
- 13) Inspect all previously repaired areas for serviceability per CF6-6 Engine Manual GEK 9266 Section 78-32-01 or CF6-50 Engine Manual GEK 50481 Section 78-32-01.
- 14) Refer to Figure 1, Sheets 1 and 2. Install three aft and three forward sound panels in the translating cowl using the hardware retained in Step 3 per CF6-6 Engine Manual GEK 9266 Section 78-32-01 or CF6-50 Engine Manual GEK 50481 Section 78-32-01.
- 15) Install the translating cowl on the fan reverser per the applicable Aircraft Maintenance Manual (AMM).
- 16) Refer to Figure 2, Sheet 1. Inspect the thrust reverser fixed structure adjacent to the translating cowl bumpers and deactivation lockplates for any indication of contact or damage. If contact or damage has occurred, adjust and shim the bumpers or deactivation plates per CF6-6 Engine Manual GEK 9266 Section 78-32-01 or CF6-50 Engine Manual GEK 50481 Section 78-32-01. Refer to Figure 6 for translating cowl bumper and lockplate to fixed structure clearances.

Middle River Aircraft Systems

**Fan Reverser
Service Memorandum**

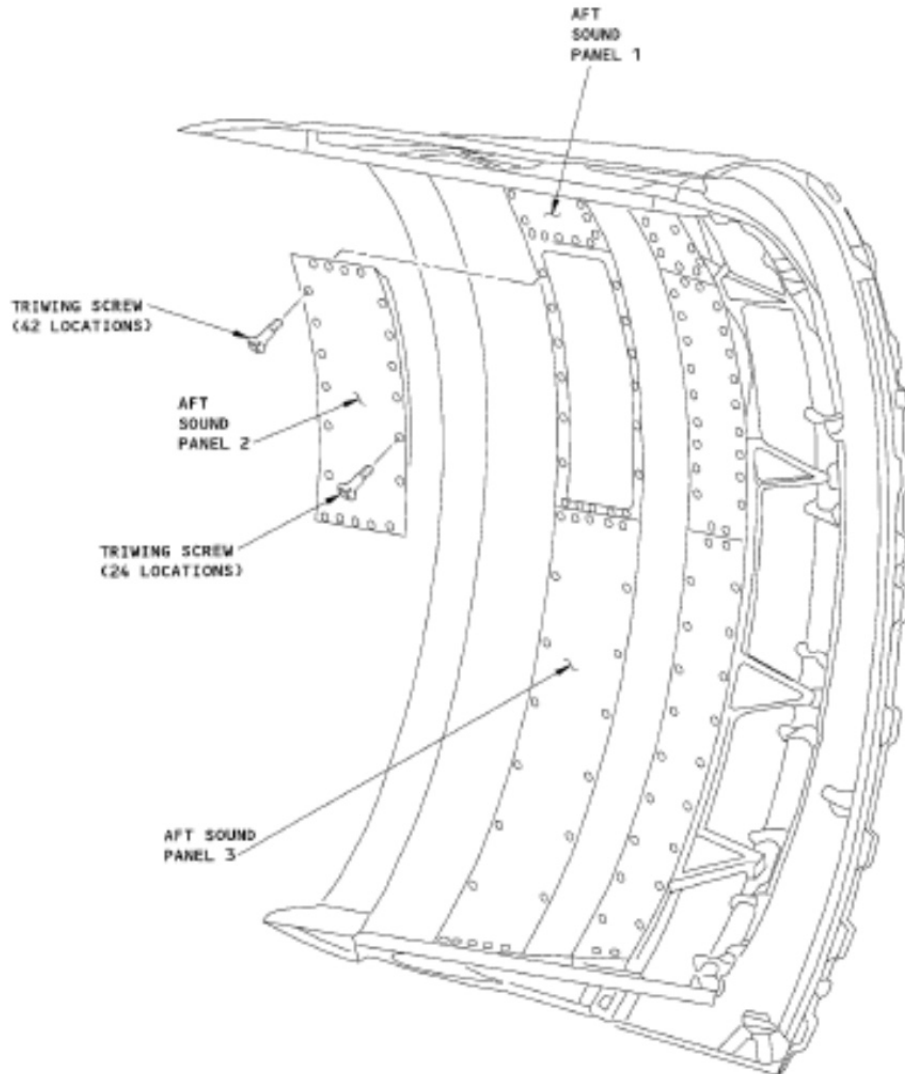

MR70894-01-A

Translating Cowl Sound Panel Removal and Installation
Figure 1, Sheet 1 of 2

Middle River Aircraft Systems

**Fan Reverser
Service Memorandum**

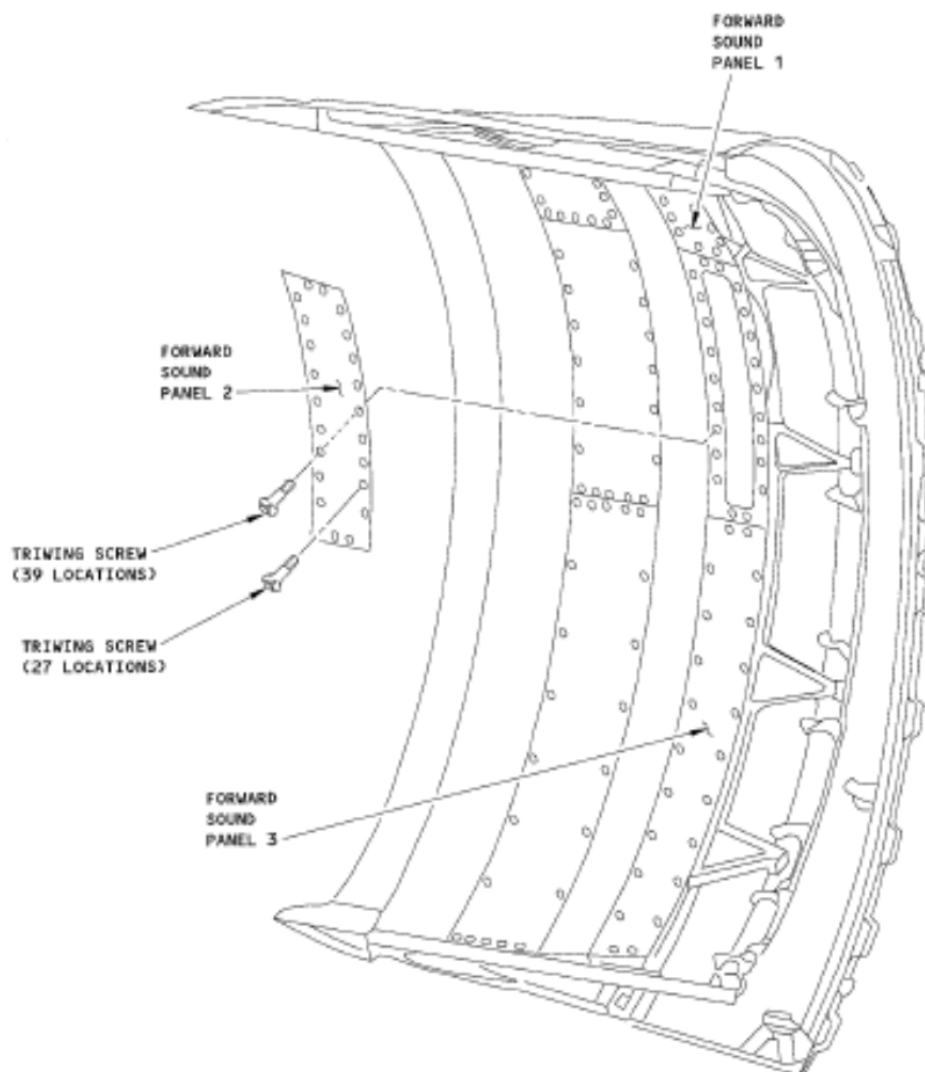

MR70898-00-A

Translating Cowl Sound Panel Removal and Installation
Figure 1, Sheet 2 of 2

Middle River Aircraft Systems

Fan Reverser Service Memorandum
--

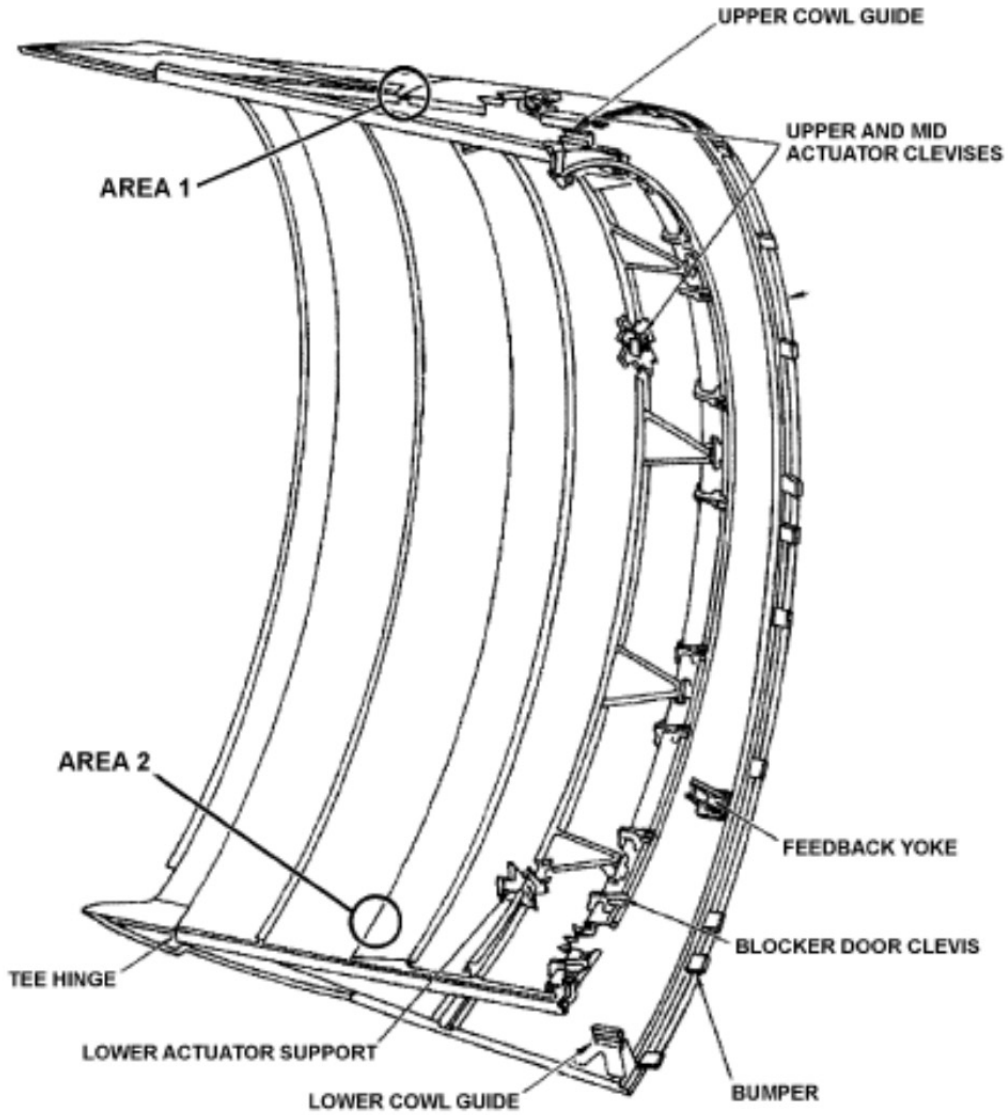

MR70895-00-A

Translating Cowl Inspection Areas
Figure 2, Sheet 1 of 3

Middle River Aircraft Systems

**Fan Reverser
Service Memorandum**

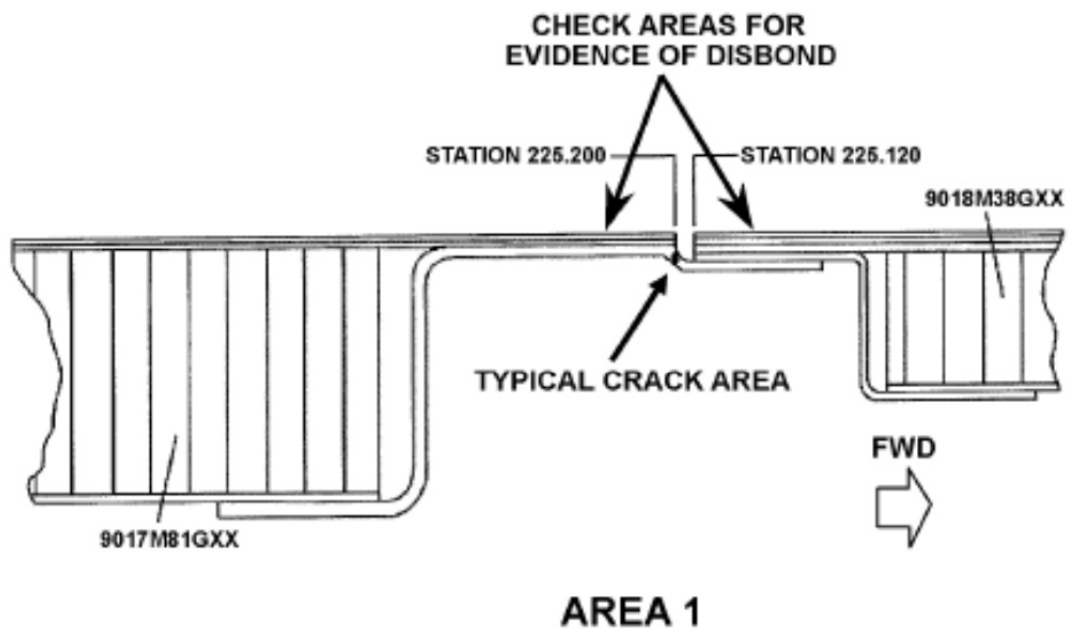

MR70896-01-A

Translating Cowl Inspection Areas
Figure 2, Sheet 2 of 3

Middle River Aircraft Systems

**Fan Reverser
Service Memorandum**

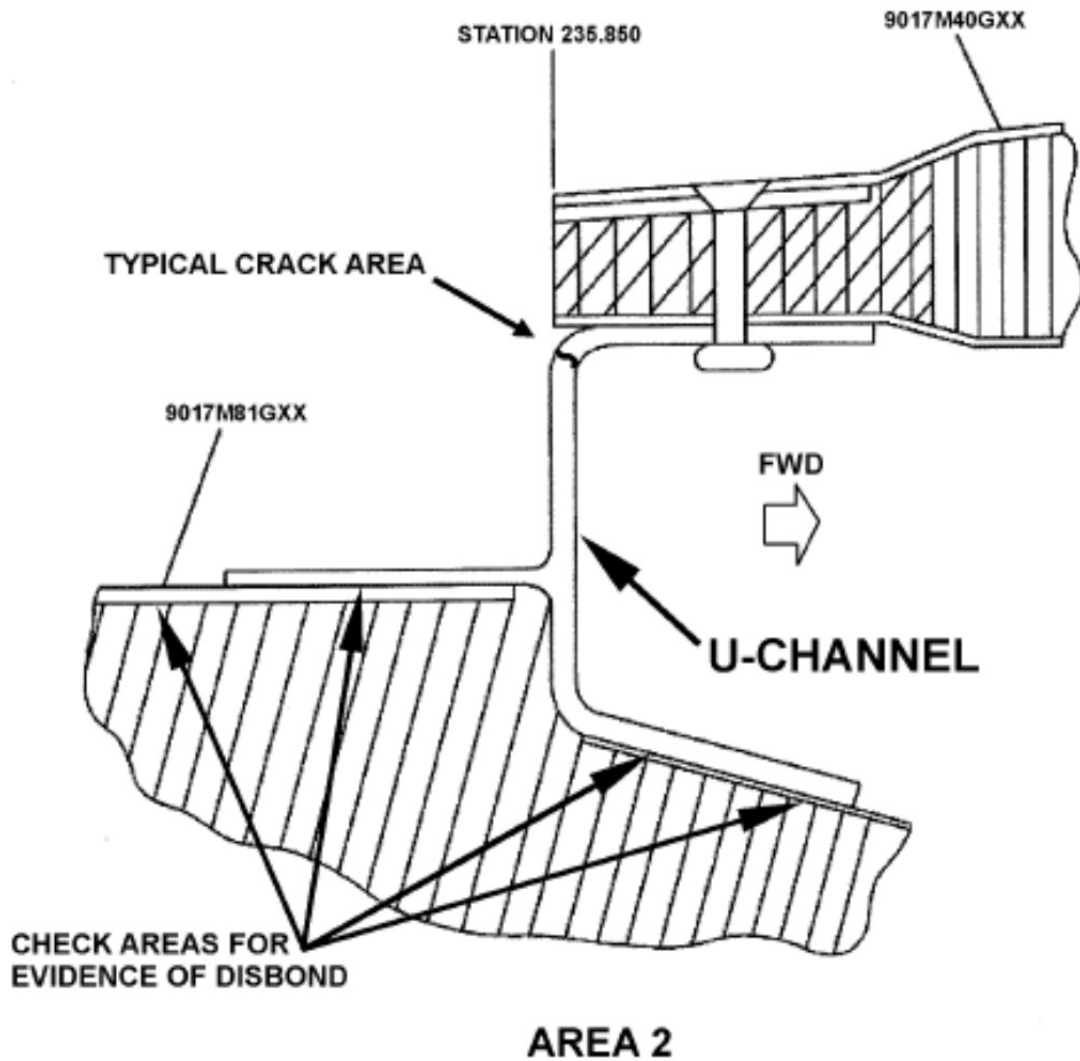

MR70897-02-A

Translating Cowl Inspection Areas
Figure 2, Sheet 3 of 3

Middle River Aircraft Systems

 Fan Reverser
 Service Memorandum

NOTE:

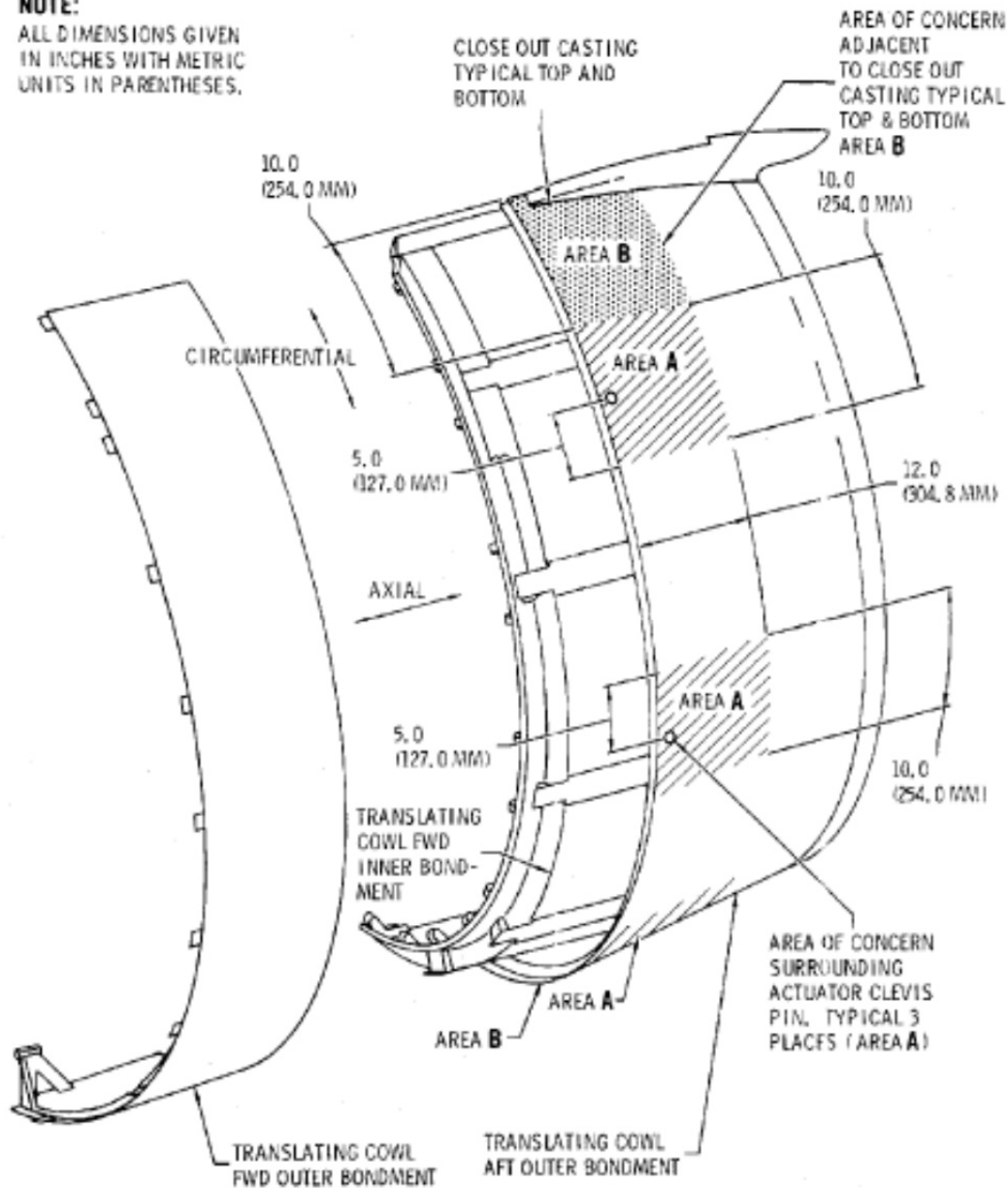
 ALL DIMENSIONS GIVEN
 IN INCHES WITH METRIC
 UNITS IN PARENTHESES.

MR70906-00-A

 Translating Cowl Disbonds Areas of Concern
 Figure 3

Middle River Aircraft Systems

**Fan Reverser
Service Memorandum**

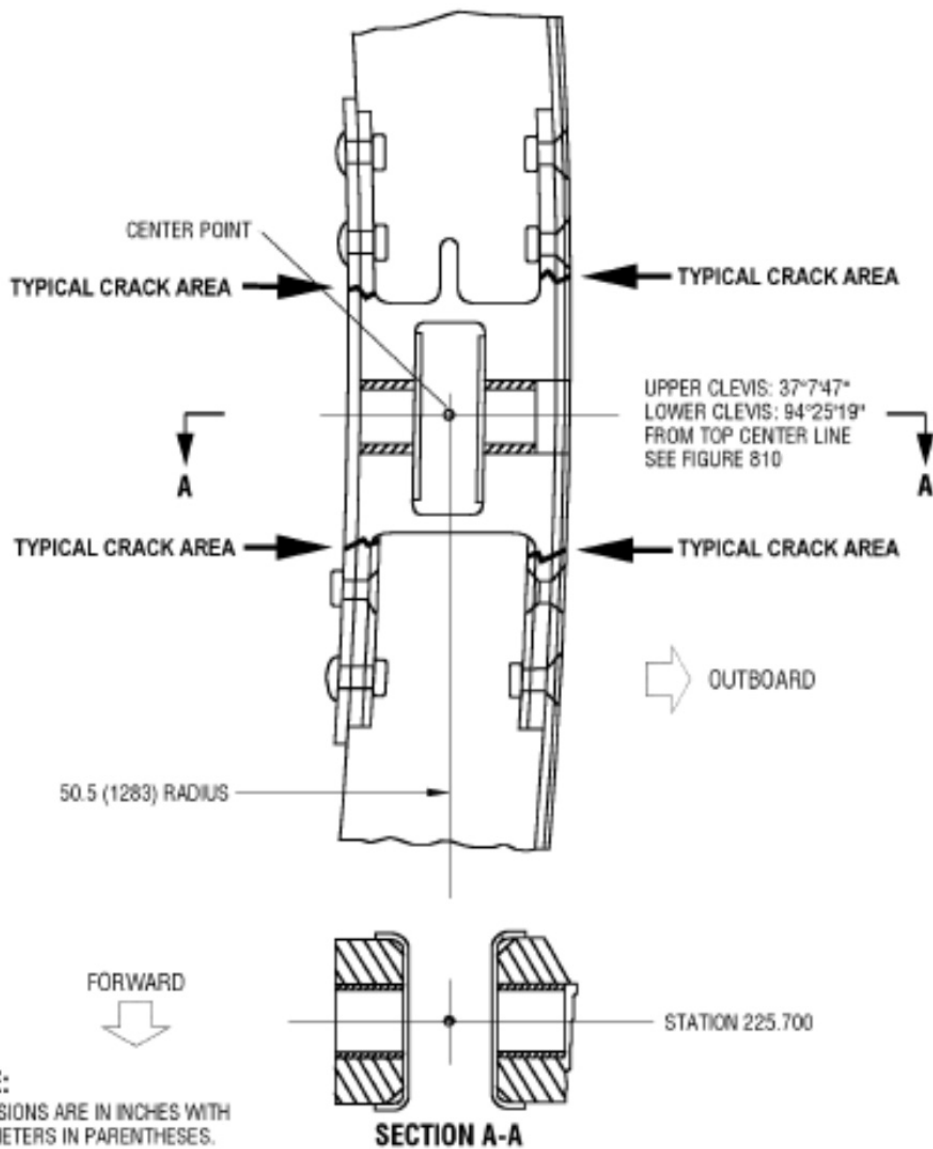

MR70907-00-A

Translating Cowl Upper and Mid Clevis Area Inspection
Figure 4

Middle River Aircraft Systems

<p>Fan Reverser Service Memorandum</p>

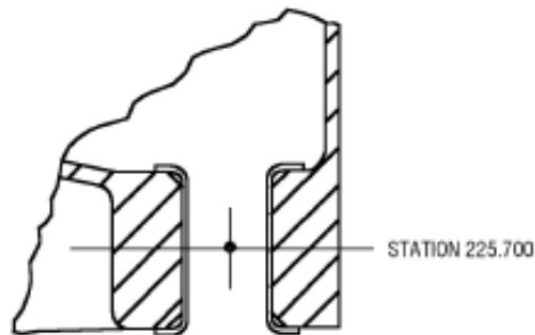
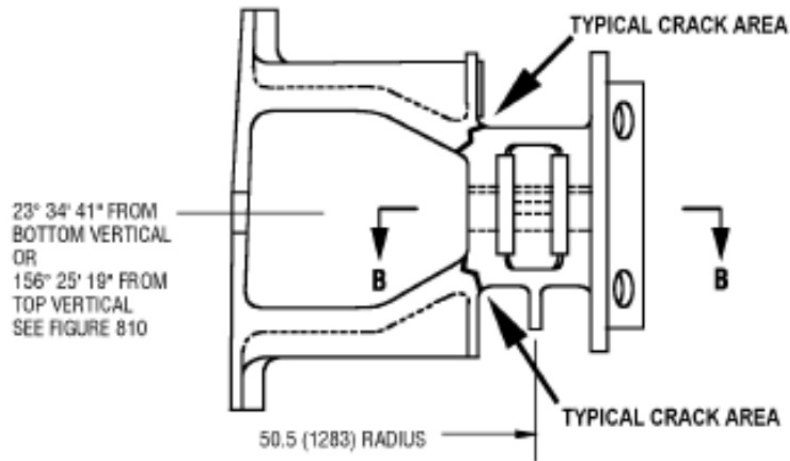

SECTION B-B

NOTE:
DIMENSIONS ARE IN INCHES WITH
MILLIMETERS IN PARENTHESES.

MR70908-00-A

Translating Cowl Lower Actuator Support Inspection
Figure 5

Middle River Aircraft Systems

**Fan Reverser
Service Memorandum**

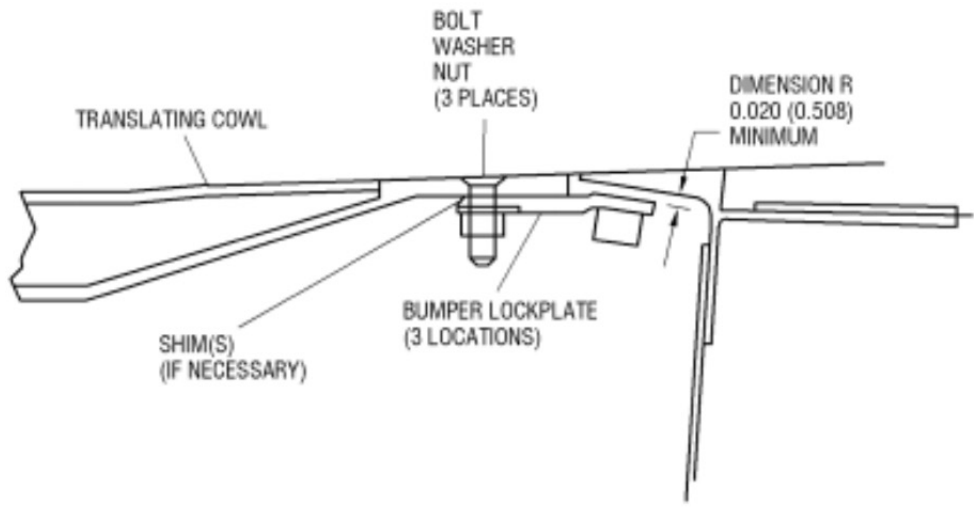
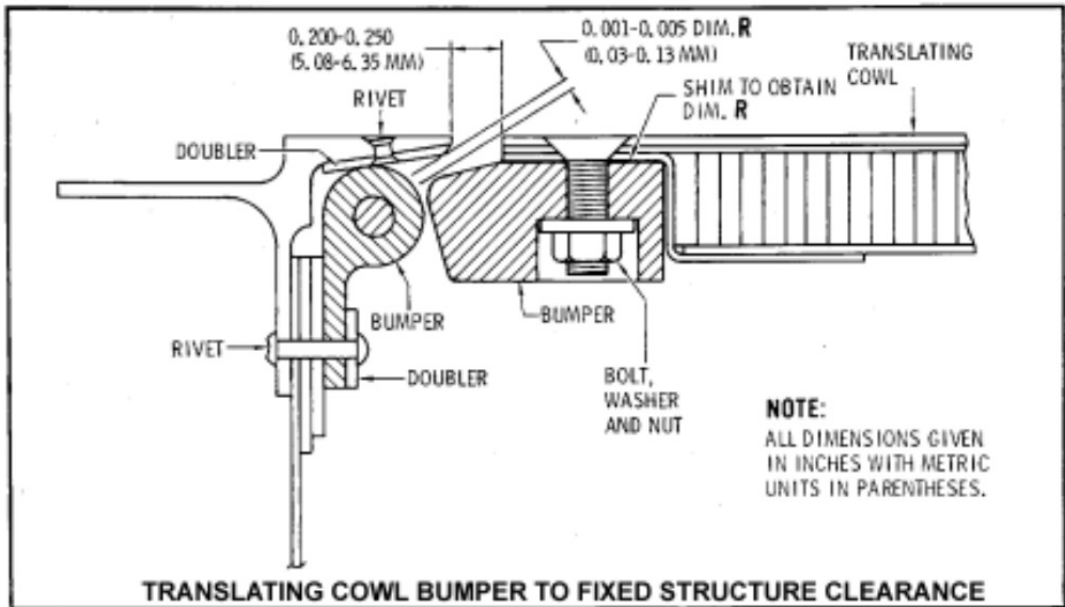

MR70917-00-A

Translating Cowl Bumper and Lockplate to Fixed Structure Clearances
Figure 6

This investigation was conducted in accordance with the regulation (EU) No. 996/2010 of the European Parliament and of the Council of 20 October 2010 on the investigation and prevention of accidents and incidents in civil aviation and the Federal German Law relating to the investigation of accidents and incidents associated with the operation of civil aircraft (*Flugunfall-Untersuchungs-Gesetz - FIUUG*) of 26 August 1998.

The sole objective of the investigation is to prevent future accidents and incidents. The investigation does not seek to ascertain blame or apportion legal liability for any claims that may arise.

This document is a translation of the German Investigation Report. Although every effort was made for the translation to be accurate, in the event of any discrepancies the original German document is the authentic version.

Published by:

Bundesstelle für
Flugunfalluntersuchung
Hermann-Blenk-Str. 16
38108 Braunschweig

Phone +49 531 35 48 - 0
Fax +49 531 35 48 - 246

Mail box@bfu-web.de
Internet www.bfu-web.de