

Final Report

CX002-0/01
Mai 2003

Basic Information

Type of Occurrence: Accident
Date: 08. February 2001
Location: Nürnberg / Germany
Aircraft: Airplane
Manufacturer, Model: Learjet LR35A
Injuries to Persons: Fatal
Damage: destroyed
Other Damage: minor

Final Report

CX002-0/01
Mai 2003

Basic Information

Type of Occurrence:	Accident
Date:	08. February 2001
Location:	Nürnberg / Germany
Aircraft:	Airplane
Manufacturer, Model:	Learjet LR35A
Injuries to Persons:	Fatal
Damage:	destroyed
Other Damage:	minor

Relating to the Investigation into Accidents and Incidents Associated with the Operation of Civil Aircraft (Flugunfall-Untersuchungs-Gesetz - FIUUG) dated 26 August 1998.

According to this Law, the sole objective of the investigation shall be the prevention of accidents and incidents. It is not the purpose of this activity to apportion blame or liability.

mail: box@bfu-web.de	Published/Sale:
http://www.bfu-web.de	Bundesstelle für
Tel: +49 531 35 48 0	Flugunfalluntersuchung
Fax: +49 531 35 48 246	Hermann-Blenk-Str. 16
	38108 Braunschweig
	Germany

Table of Content

Synopsis	4
1. Factual Information	5
1.1 History of the flight	5
1.2 Injuries to persons	7
1.3 Damage to aircraft	7
1.4 Other damage	7
1.5 Personnel information.....	8
1.5.1 Pilot in command	8
1.5.2. Second Pilot.....	8
1.6 Aircraft information.....	8
1.7 Meteorological information	11
1.8 Aids to navigation	11
1.9 Communication.....	11
1.10 Aerodrome information	11
1.11 Flight Recorders	12
1.12 Wreckage and impact information	12
1.13 Medical and pathological information	15
1.14 Fire.....	16
1.15 Survival aspects.....	16
1.16 Test and research.....	16
1.17 Organizational and management information	17
1.18 Additional information	17
1.19 Useful or effective investigation techniques	17
2. Analysis	17
3. Conclusions	29
3.1 Findings	29
3.2 Causes.....	30
4. Safety Recommendations	30
5. Appendices	31

Synopsis

On Thursday, 08.02.2001 at 1545 o'clock local time, the Federal Bureau of Aircraft Accidents Investigation (BFU) was notified by a commissioner for flight accident investigation at Nuernberg airport that a Learjet had crashed during the approach to runway 10 approximately 300 meters north of the runway threshold in a forest. Four minutes after the departure from Nürnberg the pilots had reported an engine failure and had decided to return to the airport. There had been an impact fire, which was extinguished by the airport fire services. The three occupants had been killed in the accident.

Three employees of the BFU arrived at the accident site by 2030 o'clock. The investigations on site started the same day. On the third day the representatives of the State of Registration and of the Operator, Italy, and the State of Manufacturer, USA, arrived with their advisors at the accident site. In total

- 2 employees of the National Transportation Safety Board (NTSB, USA)
- 1 employee of the Agenzia Nazionale per la Sicurezza del Volo (ANSV, Italy)
- 1 employee of the Federal Aviation Administration (FAA Office of Accident Investigation USA) (advisor)
- 1 employee of Honeywell (Engine manufacturer — USA) (advisor)
- 4 employees of Bombardier Aerospace (Learjet USA) (advisor)

were at the accident site and later on with the BFU in Braunschweig, and with Honeywell in Raunheim/Germany, in accordance with the Law Relating to the Investigation into Accidents and Incidents Associated with the Operation of Civil Aircraft and Annex 13 ICAO.

At the accident site, the following working groups were formed:

- Working Group 1 Operations; Air Traffic Control (ATC); Airport; Weather
- Working Group 2 Power Plants;
- Working Group 3 Systems & Structure

And in addition with the BFU in Braunschweig

- Working Group 4 Flight Data Recorder
- Working Group 5 Flight and Power Plant Instruments

The results of the investigation are based on:

- Investigations on the wreckage and at the accident site;
- Testimonies, picture and video recordings;
- Evaluation of the operation documentation and airplane manuals;
- Evaluation of the repair and maintenance documentation;
- Investigation of engine and flight guidance instruments;
- Evaluation of the voice recordings by the air traffic control;
- Evaluation of the radar recordings by the air traffic control;
- Investigation of the power plants;
- Evaluation of the Flight Data Recorder and the Cockpit Voice Recorder.

The accident was caused by an in-flight failure of the left power plant appr. 3 minutes after take-off and an inadequate conduct of the subsequent single-engine landing procedure so that in short final the airplane stalled and crashed from low height.

The failure of the left engine was caused by intergranular fractures of retention posts on the high pressure turbine disk. As a result of incorrect service life recordings the maximum number of cycles had considerably been exceeded.

1. Factual Information

1.1 History of the flight

During an inspection of the right engine a technician found chips in the oil filter. The damage should have been repaired within the next 20 flight hours. Since the maintenance organization in Switzerland, who usually carry out necessary repairs, did not have the spare parts available on time, the task was assigned to an organization in Nuernberg. On 07.02.2001, the airplane was ferried to Nuernberg and repaired in the presence of the chief technician of the operator. The repairs and the replacement of the parts exclusively on the right engine were certified properly.

The return flight to Rome was planned for the 8th of February 2001 at about 1530 o'clock. A charter flight from Rome was to be carried out on the following day. Two pilots and the chief technician of the operator were aboard the aircraft. The flight preparation was carried out by phone from the repair facility. A weather briefing and the NOTAM's for the flight were ob-

tained properly. The check lists for the take-off were read. During the preparation the unbalanced fuel distribution between the right and left-hand tanks, and the fact that the total amount yet was equal on both sides was discussed. Immediately afterwards the second pilot noticed the failure of his gyro instruments. The airplane was taxied via the taxi ways "Juliet" and "Foxtrot" to runway 10. Pilot at the controls was the pilot in command while the second pilot carried out the radio communications with the air traffic control.

The pilots received the clearance for a departure via the departure route Noerdlingen (NDG 1 M) to Rome. The take-off was at 1531 o'clock. After 5 nautical miles the airplane turned to the south, following the departure route. At 15:33:49 o'clock the left-hand engine failed without a previous warning. The noise of a down running engine was also heard by several witnesses on the ground. Smoke or a fire was not seen by them.

The second pilot reported an emergency with the left-hand engine shortly after the occurrence to the control tower and informed them that they wanted to return for a landing on the runway 10. At that time there were visual meteorological conditions, and the runway was continuously to be seen. Since the departure control Nuernber APP wished to coordinate the flight, the frequency was changed for a short time upon request. After the second pilot had declared the emergency once again they switched back to the tower again and continued the approach to runway 10.

Up to the final approach the flight was without particular occurrences. The flaps were first set to 8° and later on to 20°, afterwards the landing gear was extended. At this time the airplane was somewhat north of the extended center line slightly above the glide path for an instrument approach. Approximately one kilometer in front of the runway, when flying over the main road no. 4 near the small town of Buch, the airplane was observed by different witnesses as it made unusual flight maneuvers. The airplane deviated then from the landing direction to the north, and made some reeling movements. Afterwards it seemed for a short period that the pilot intended to turn right to reach the runway. Immediately afterwards and near the ground the airplane abruptly stalled to the left approximately maintaining its height, then assuming a bank angle of more than 90°, and crashed nearly upside down at 1540 o'clock into a forest north of the runway.

The airport fire service, who were in a standby position due to the announced safety landing of the Learjet reached the accident site approximately 4 minutes later and started to extinguish the fire. All three occupants had lost their lives during the impact. The airplane was destroyed.

The investigation revealed that the airplane had cut several trees at the beginning of a forest with a heading of approx. 037° under a flat angle and crashed on the ground in an almost inverted flight attitude approximately 230 meters north of the beginning of runway 10.

All parts of the airplane were found in the surroundings of the accident site and documented as far as possible. The left engine had obviously not been running during the impact whereas the right engine showed clear signs of a high rotation. The power plant instruments recovered later on indicated similar values. The airplane and the maintenance documentation, and most of the personal documents of the crew as well as the flight preparation documents, were recovered almost completely at the accident site. On the second day the owner of the airplane was at the accident site and could give important information about the airplane, the repair of the engine and the occupants.

1.2 Injuries to persons

In the accident both pilots and the technician on board were killed by the impact on the ground

Injuries	Crew	Passengers	Others
Fatal	2	1	0
Serious	0	0	0
Minor/None	0	0	

1.3 Damage to aircraft

The airplane was destroyed by the impact on the trees and on the ground.

1.4 Other damage

On the flight path into the forest and caused by the subsequent fire severe damage to the forest had arisen.

1.5 Personnel information

1.5.1 Pilot in command

- male, 33 years, Italian citizen
- commercial pilot, CPL no. 11222, valid until 12.04.2005
- ATPL check flight passed on 08.01.2001
- type rating LR35A
- instrument rating, valid
- total flight hours: 2641 h
- flight hours LR35A: 54:44 h
- aero medical examination on 19.09.2000
- class I, without restrictions

1.5.2. Second Pilot

- male, 22 years, Italian citizen
- commercial pilot, CPL no. 10630, valid until 10.03.2005
- type rating LR35A
- instrument rating, valid
- total flight hours: 575 h
- flight hours LR35A: 192 h
- aero medical examination on 19.09.2000
- class I, without restrictions

1.6 Aircraft information

The Learjet is a twin jet business airplane with a maximum take-off mass of 8300 kg. The airplane has a maximum seating capacity for two pilots and eight passengers.

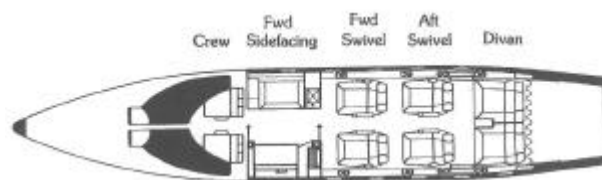

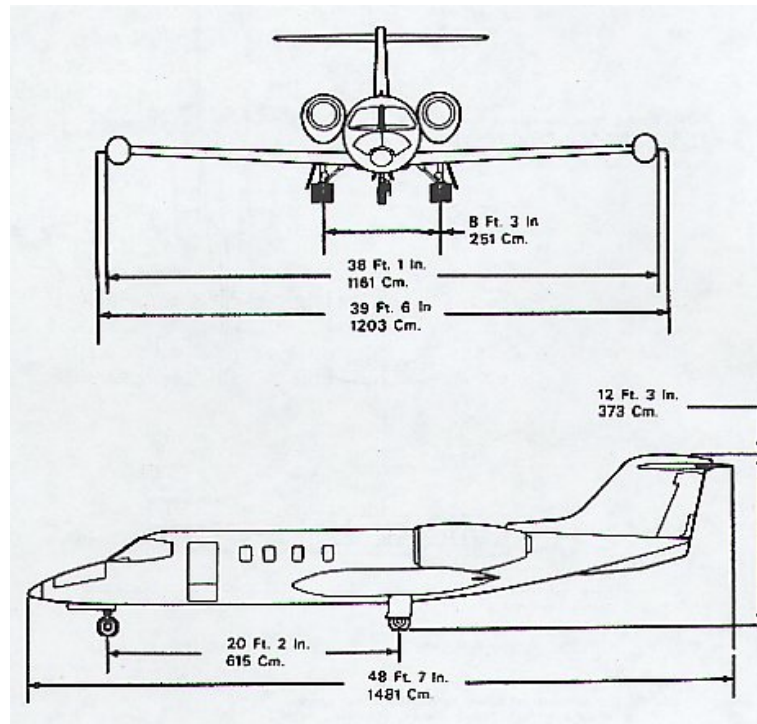

- type: Learjet LR35A
- manufacturer: Gates Learjet Co., Wichita USA
- year of manufacture: 1981
- serial number: 35A-445
- category: transport of passengers
- power plants: 2 turbo fan, Honeywell Engine systems (formerly: Allied Signal Aerospace)
- model: TFE731-2-2B
- engine 1(left-hand): P/N 3070300-9 S/N P89224
- engine 2 (right-hand): P/N 3070300-9 S/N P89223

The TFE731 power plant is a two-spool turbo fan jet engine with a single-stage gear driven fan. The fan is driven by the low pressure spool (LP) through a planetary gear system. The low-pressure spool consists of a four-stage axial compressor, driven, along with the fan, by a three-stage axial turbine. The high pressure spool (HP) consist of a single-stage centrifugal compressor driven by a single-stage axial turbine. The engine and aircraft accessories are driven by the HP spool through the accessory gearbox mounted at the lower part of the engine. The combustion section of the engine consists of a single annular, reverse flow combustor, 12 fuel nozzles and two electrical igniters.

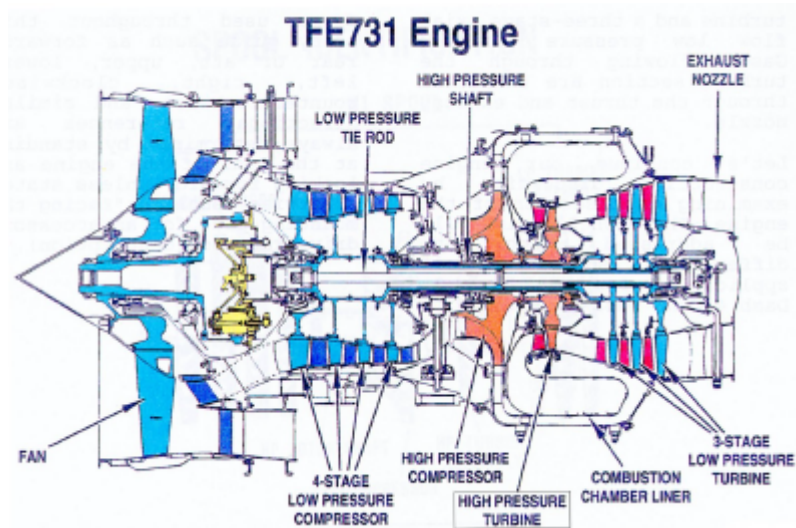

On engine no. 2 (right engine) repairs had been carried out in Nürnberg; engine no. 1 (left engine) had failed during the departure procedure. The engines had been torn off their attachments during the impact. In agreement with the prosecution authorities both engines were placed in custody, and shipped to Honeywell in Raunheim/Germany for further investigations. During the investigation of the engines and the relevant instruments the following parameters were determined:

	left engine	right engine
fan speed (%N1)	00.0	91.4
turbine speed (%N2)	00.0	96.4
ITT (C°)	967	824

From these values indicated for the time of the impact it is to be concluded that the left engine was not running, and the right engine was running at a high power.

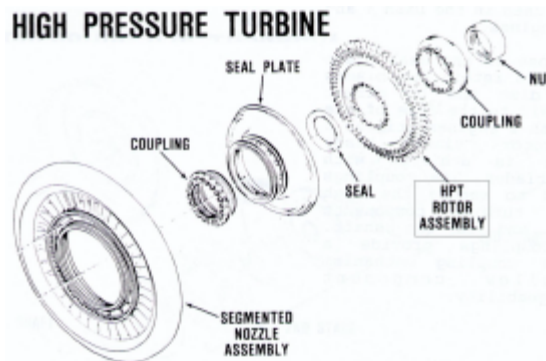

1.7 Meteorological information

During the flight and at the time of accident the meteorological information indicated CAVOK (Ceiling and Visibility OK, ceiling >5000 ft, visibility >10 000 m). The wind came from 140 degrees with 2 knots, the ambient pressure was 1003 hPa. There were no obstructions to visibility.

1.8 Aids to navigation

According to the information of the central of air traffic control all navigation aids available worked without deficiencies. After the failure of the left-hand engine the flight which lasted 10 minutes in total was continued under visual flight conditions.

1.9 Communication

The radio communications took place in English language and were recorded by the air traffic control. During the take-off and the landing communications with the tower took place on the frequency 118.3 MHz. The Jeppesen contains a remark "immediately after take-off contact Nürnberg radar". On this basis the pilot was requested to change to departure control on 119.525 MHz after the engine failure. After the pilot had once again declared on this frequency that the airplane had an emergency and that it was approaching Nürnberg, it was transferred back to the tower. All conversations between the crashed airplane and air traffic control were available for the evaluation. The telephone calls between the air traffic control units had also been recorded and were available for the investigation.

1.10 Aerodrome information

The airport is situated immediately northwest of the city of Nürnberg

- name: Nürnberg Airport
- ICAO Identifier: EDDN
- landing direction: 279° / 099° (28/10)
- Runway length: 2 700 m (Concrete/asphalt)
- Runway Elevation: 1 021 ft THR RWY 10
- Visual App Aid: PAPI 3°

1.11 Flight Recorders

The Flight Data Recorder (FDR) is a

- digital Flight Data Recorder
- Fairchild, Model F 800
- P/N 17 M 703-274
- S/N 5223 - plastics Tape, 6 traces.

The Cockpit Voice Recorder (CVR) is a

- Collins Voice Recorder
- Type 642C-1, 4 channels (Pilot/Co-Pilot/Area-Mic/Aux.)
- P/N 522-4057-001
- S/N 3917

Both recorders were recovered at the accident site and brought to Braunschweig for evaluation. The data were readable and helpful for the investigation.

In addition, a satellite navigation device, GPS Trimble 2101 I/O plus, had been installed. Although it was found during the recovery already that the device was dented and covered with soot, the BFU attempted in the lab to read out possibly available data. When the GPS was opened the battery for the data storage was found to be destroyed by the fire and the data were not readable anymore.

1.12 Wreckage and impact information

The position of the accident site is approximately 230 meters north of the threshold of runway 10 of Nürnberg airport, still in the attainment district of the City of Erlangen, at the beginning of a wooded area close to the small town of Kraftshof. On a course of approximately 037° the trunks of nine trees had been cut through indicating a flat impact angle of 13 to 15 degrees. During the flight through the trees the airplane had rolled by appr. 220° about the longitudinal axis into an inverted flight attitude. The airplane came to rest in an upside down position approximately 100 meters from the first collision with trees on a final heading of 353°. On the last 60 meters on this track to the wreckage there had been a strong fire, and parts of the airplane and its contents were distributed along the route.



The fuselage of the airplane had been destroyed by the ground impact and the subsequent fire. The tail section was heavily damaged. The horizontal tail had been torn off and was found under the left-hand wing. These parts, however, were not damaged by the fire. For the most part the rudder and trim positions could be determined. The rudder trim was observed to be in a centered position. The flaps were in a position between sixteen and twenty degrees. The flap lever in the cockpit was set to 20 degrees.

The left main landing gear was down and locked. The right main landing gear and nose wheel assembly were torn off their attachment points. The gear lever was in the down position.

The left-hand engine was found at a distance of several meters from the main wreckage. The right engine was lying on the wreckage. The left wing had separated from the fuselage. The fan blades of the left-hand engine did not show any traces of rotation. The right jet engine had obviously been rotating with high power. The indications of the engine instruments, which were discovered later on, were in conformity with the traces found on the engines. Caused by the impact, both thrust levers were in the neutral position.

The cockpit and the entire front section of the airplane were destroyed. The second pilot and the passenger were found to the left in front of the wreckage, partially still in the airplane wreckage. In the center section of the wreckage, in the wing attachment area, distinct traces of a fire were to be seen. The tail was lying on the right side. The airplane documents from a flight case were scattered in the direction of impact over approx. 8 meters on the ground. The pilot's seat was found approximately two meters further on. The seat belts had been torn off their attachment points at the seat. The position of the pilot in command was four meters further on.



Cockpit Area

The flight data recorder was found in front of the tail section. The cockpit voice recorder was still in the wreckage. Both recorders were recovered and brought to Braunschweig for evaluation. On the second day it was stated that a signal of the ELT (Electronic Locator Transmitter) was still received in Toulouse. The transmitter could be located in the airplane and switched off.



Left Wing and Landing Gear

All parts of the airplane were found at the accident site as far as they had not been destroyed by the fire. All damage found had been caused by the impact. This is also true for the pointer positions of the flight and engine instruments as well as the lever and switch positions.



Tail Section and Flight Data Recorder

1.13 Medical and pathological information

All three occupants died of the direct consequences of the impact forces.

1.14 Fire

Immediately after the impact a violent fire arose as a result of kerosene leaking out; the airport fire service arrived approximately four minutes after the accident and the fire could be extinguished rapidly. The fuselage had been destroyed by the fire. Many trees in the area of the impact site had been damaged severely.

1.15 Survival aspects

The accident was not survivable for the occupants of the airplane.

1.16 Test and research

Both engines of the airplane were brought to Honeywell at Raunheim where they were examined under the management of the NTSB and under supervision of an employee of the BFU. The investigations showed that on the left engine the turbine blade attachments (fir tree posts) of the high pressure turbine disk, PN 3072732-3, SN 8-23315-1257, had burst leading to the loss of four turbine blades. The burst turbine disc was brought to Braunschweig for a material investigation. The right engine, which had been repaired at Nuernberg prior to the accident, only showed damage to be attributed to the impact.

The engine instruments and some of the flight guidance instruments were examined in the laboratory of the BFU for impact marks and probable indications at the moment of the impact.

All technical and aviation documents found in the airplane wreckage were evaluated in Braunschweig with the assistance of the Italian operator and the Italian investigation authority.

On the basis of the radar recordings of the German ATC the flight was reconstructed with the calculations of the track and particularly the speeds during the last portion of the flight.

The evaluation of the flight data recorders in comparison with the air traffic control recordings produced a good image of the flight technical processes even though only four parameters had been recorded. This is also true for the evaluation of the Cockpit Voice Recorder (CVR). as the pilot in command and the chief technician of the operator came from Argentina, the conversation in the cockpit took place in Italian, Spanish and English. With

the support of the operator and a Spanish speaking pilot of Lufthansa Airlines a transcription of the tape and an attribution of the voices could be completed.

By a spectrum analysis of the engine frequencies on the basis of the CVR recordings it could be verified that in the final approach the remaining right engine was running maximum power for a short time.

1.17 Organizational and management information

not applicable

1.18 Additional information

none

1.19 Useful or effective investigation techniques

The standard techniques were applied

2. Analysis

During a 150 hrs inspection of the airplane, metal chips were found in the oil filter of the right-hand power plant. An oil sample was sent to the manufacturer for the purpose of investigation revealing a bearing damage in the gear box. Upon further enquiry the technical director of the air carrier was informed that after discovering of the damage a maximum of twenty flight hours would be allowable. As since then already 18 hours had been flown, the operator tried to have the damaged parts replaced by a Swiss maintenance organization, who have performed all major repairs on the airplane within the preceding five years. This organization, however, did not have the required components available at short notice. The organization in Nürnberg, with whom the operator had already cooperated formerly, was in a position to accomplish the required repair at once. Thus the Learjet was ferried by two pilots and the technical director in the evening of 07.02.2001 from Triest to Nürnberg. The repair including the necessary entries in the technical logbook lasted until 08.02.2001 appr.

14:00 hrs. The departure to Rome, where the airplane was needed for a planned flight on the next day, was scheduled for 15:00 hrs. The airplane was fueled and an IFR flight plan filed with the air navigation services.

Aboard the airplane, the check lists for the preparation of the flight and engine starting were read. On this occasion the pilots noticed that the tip tanks on the right side and on the left side were filled unevenly. After a short discussion the pilots decided that it was possible to fly with the tip tanks filled unevenly as the total fuel quantities were equal on both sides. The second pilot noticed that the gyro system on his side had failed. The technical director said they should leave it like this for the whole flight and replace the gyro system afterwards. After starting up of the power plants the pilot-in-command had slight orientation problems when taxiing to runway 10. Whereas the pilot-in-command was piloting the Lear-jet, the second pilot read the check lists and communicated with the air traffic control units. After having received the take-off clearance the take-off was performed professionally. The planned departure route towards Noerdlingen (NGD1M) was followed and it was intended to climb to FL 70 (7000 ft).

A little less than 3 minutes after the take-off at an altitude of appr. 5900 ft and an airspeed of 250 kt the failure of one of the power plants is clearly to be heard on the cockpit voice recorder. The second pilot informed Nürnberg tower that they had an emergency because of the failure of the left power plant and that they intended to initiate a descent for landing. The tower controller confirmed receipt of the message and requested the crew to contact radar on the frequency 118.97 as they were responsible for the airspace concerned.

The crew of the airplane had not observed the provision of the AIP AD 2 EDDN 5-7-5 that after the take-off Nürnberg Radar is to be contacted immediately (Contact Nürnberg Radar immediately after take-off). The reason could not be determined anymore. The failure of the left power plant had not announced itself but occurred suddenly and unexpectedly shortly before the controller requested the crew at 15:33:44 to change to Nürnberg Radar; thus before this moment there was no increased work load in the cockpit caused by the engine failure.

A request for a frequency change after receipt of the message '...we have an emergency on a left engine we are descend to come back ...' without taking an action adapted to the situation, e.g. clarification of the situation on board, is extremely problematic. The 'Betriebsan-

weisung fuer die Flugverkehrskontrolle (BA-FVK)' (operating instructions for air traffic control) contains the following provision under subpara 611.2:

All possible actions are to be taken immediately in order to give assistance to an aircraft which is known to be in an emergency in order to support the aircraft in question.

This provision had not been observed by the controller as he did not know to what extent the reported emergency had an effect on the flight characteristics of the aircraft and the ability of the crew to act. Instead the crew was instructed to change the frequency, an action which, as there was no conflicting traffic near the Learjet, most probably would have shown to be unnecessary, if the controller had contacted the responsible unit (Nürnberg radar). The crew had to change the frequency once again back to the tower after they had informed radar about the situation on board as well as their decision to return to Nürnberg. In addition, the crew had to confirm once again that they had declared an emergency. This frequency change diverted the crew from other tasks and meant an unnecessary loss of time.

After having contacted Nürnberg radar, the second pilot informed them that the airplane was at FL60 and once again confirmed the emergency. The airplane was cleared for a visual approach to runway 10. The question by the air navigation service whether assistance was needed was answered in the negative by the crew. Thus the crew was instructed to switch back to the frequency 118.3 MHz, control tower Nürnberg. The whole procedure took almost 2 minutes. Having contacted the tower again, the crew received a clearance for runway 10 and was asked whether the airport fire services should be in standby. Since the crew had not understood this question immediately they were once again requested to confirm that they had declared an emergency.

The weather was not a factor in the whole occurrence.

With the left power plant failing the increased strain on the pilots was clearly to be heard on the cockpit voice recorder. Whereas the pilot-in-command reacted calmly again, when he was able to judge the situation, the second pilot continued to be under strain. This became apparent in particular by the permanent clicking of the ball pen. The 'engine failure - shut down in flight' check list had not been used. The pilot-in-command first demanded the 'descent check list' and afterwards the 'before landing check list'. Both check lists are to be

used for the normal procedures and were done only partly and not systematically. Obviously the pilots did without it since the airport was clearly visible and the approach under visual meteorological conditions seemed to be possible without problems. The airspeed for the approach had not been calculated. The reference markings were still on 122 and 124 kt respectively.

Six nautical miles in front of the runway, the landing gear was extended and the flaps were set to 8°. During the turn into the final approach the airplane was slightly north of the extended center line at a speed of appr. 155 kt above the 3° glide slope for an instrument approach to runway 10. The remaining power plant was set to idle obviously in order to reduce the airspeed. By direction of the pilot-in-command the flaps were extended to 20° and afterwards to 40° (full flaps). When the flaps were extended to 40° the airspeed must have dropped considerably. Immediately afterwards the remaining right-hand power plant was speeded up to almost take-off power. Due to the asymmetric thrust the airplane yawed to the left at a height of 200 to 300 ft above ground. The pilot-in-command gave the instruction 'flaps 20'. The CVR indicates the retraction of the flaps to 20° was not quick enough for him, he called to the second pilot 'Do it!'. The descent rate reduced to less than 700 ft/min within 10 seconds, ten seconds later to zero and afterwards reached a slightly positive range. At last the height was 90 to 150 ft above ground.

Several witnesses had observed the whole occurrence and saw the airplane turning north at a low height. They observed it tumbling to the left and to the right. Afterwards the witnesses had the impression that the pilots tried to turn to the right to still reach the runway. Immediately afterwards the airplane stalled to the left and crashed into the nearby forest. The airplane had cut several tree tops at a very flat angle. The kerosene which leaking out inflamed at once and was burning. The airport fire service had observed the occurrence and arrived at the accident site appr. 4 minutes later. The fire could be extinguished. The accident was not survivable for the occupants.

The recordings of the flight data recorder, the cockpit voice recorder and the ATC radar data confirm the course of the occurrence observed by the witnesses. Obviously the airplane had not reached the expected airspeed with the flaps fully extended. The attempt to correct the attitude by the retraction of the flaps to 20° resulted in the fact that the airspeed was even closer to the stall speed. This supposition is verified by the observations made by the witnesses; they saw the airplane flying Dutch rolls immediately prior to the stall. The thrust increase on the right power plant up to almost take-off power at the same moment

was too late and had no success. This even intensified the yawing moment during the stall to the left and the airplane assumed an inverted flight attitude.

The procedure for a single engine landing in principle offers the possibility of a landing with full flaps. This, however, requires that the landing is ensured. Thus only the pilot will have to decide when a landing is ensured.

*Excerpt - Learjet 35 Series with FC-200 Autopilot
Crew Checklist and Quick Reference Handbook – ABNORMAL CHECKLIST, Page A-28*

SINGLE-ENGINE LANDING

- **If landing is made with flaps – DN:**
 1. Final Approach Configuration.....GEAR DN, FLAPS 20°
 2. Final Approach Speed..... $V_{REF} + 10$
 3. Landing Distance..... COMPUTED
 4. When landing is assured.....FLAPS DN, V_{REF}
- **If landing is made with flaps – 20°:**
 1. Final Landing Configuration.....GEAR DN, FLAPS 20°
 2. Approach Speed..... $V_{REF} + 10$
 3. Yaw Damper OFF PRIOR TO LAND
 4. Landing DistanceMULTIPLY BY 1.20

Generally the use of the 40° flaps position in the case of an engine failure is not normal and during training is regarded as an exceptional case, when the runway is not sufficient for a landing with 20° flaps position. Even in that case the flaps should be extended fully only when the approach and the landing are no longer in question. It is common theory, however, that the landing is generally to be performed with 20° flaps position.

If this check list had been used, the pilot would probably not have the flaps extended to 40°, in particular as the landing distance would have had to be calculated. For a landing mass of 6740 kg (14310 lbs) the landing distance would have been 915 m (3000 ft). Runway 10 in Nürnberg offers a landing distance available of 2700 m (8850 ft). In addition a drag chute was available to decelerate the airplane on the runway.

A procedure for a single-engine go-around is not separately described in the manuals of the airplane but is described in the abnormal check list two pages before the procedure for single-engine landing. (The flight crew used flight manual FM-102). As the check lists for the preparation of the single-engine landing and the possible go-around are not in a logical order, the use of the abnormal check list would have required browsing through the check list.

This in turn requires a good knowledge of the contents of the check lists and the abnormal procedures as well as a good crew coordination.

*Excerpt - Learjet 35 Series with FC-200 Autopilot
Crew Checklist and Quick Reference Handbook – ABNORMAL CHECKLIST, Page A-26*

GO AROUND (ONE ENGINE)

1. Autopilot..... DISENGAGE
2. Thrust Lever AS REQUIRED
3. Spoilers RETRACTED
4. Flaps 20°
5. Landing Gear (After Climb Established) UP
6. Climb at Approach Climb Speed (Approx. $V_{REF} + 7$)
7. Clear of Obstacles $V_{REF} + 30$ & FLAPS UP

It cannot be clarified anymore whether the pilot wanted to initiate a go around or tried to still reach the runway. It is more probable that due to his poor experience on the type the situation, which occurred suddenly, made excessive demands upon him. It is a matter of fact, however, that he had tried immediately before the crash to speed up the right hand power plant to full thrust. Power plant parameters were not available on the flight data recorder.

In order to determine the power plant parameters during the final approach up to the accident, spectrum analyses of the cockpit voice recorder were made. As the frequency of the power plant during the take-off was known a direct comparison to the frequency during approach could be made. On the basis of this comparison it was found that prior to the deviation of the airplane from the extended center line to the north the right-hand power plant had take-off power.

Spectrum Analyses CVR - Engine Failure - (Pilots' Channel only)

The red marks are voice recordings. For better perceptibility the trace has been highlighted and colored in red

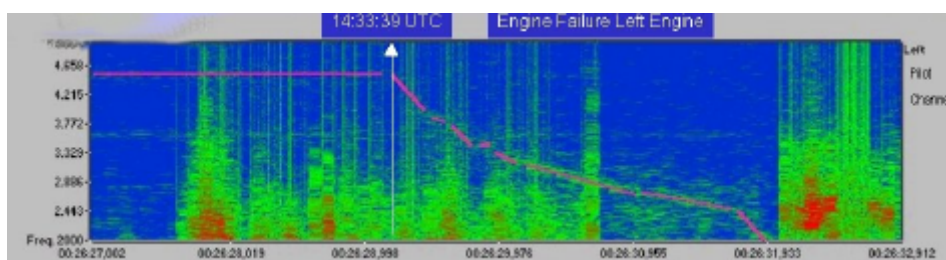

Engine Noise last 3 Minutes - (CVR - Pilots' Channel only)

For better perceptibility the trace has been highlighted and colored in yellow

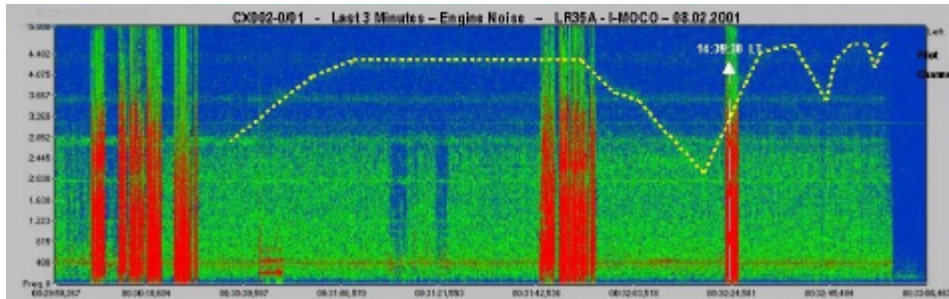

X-REPLAY – Radar data – total Flight - DFS (Excerpt)

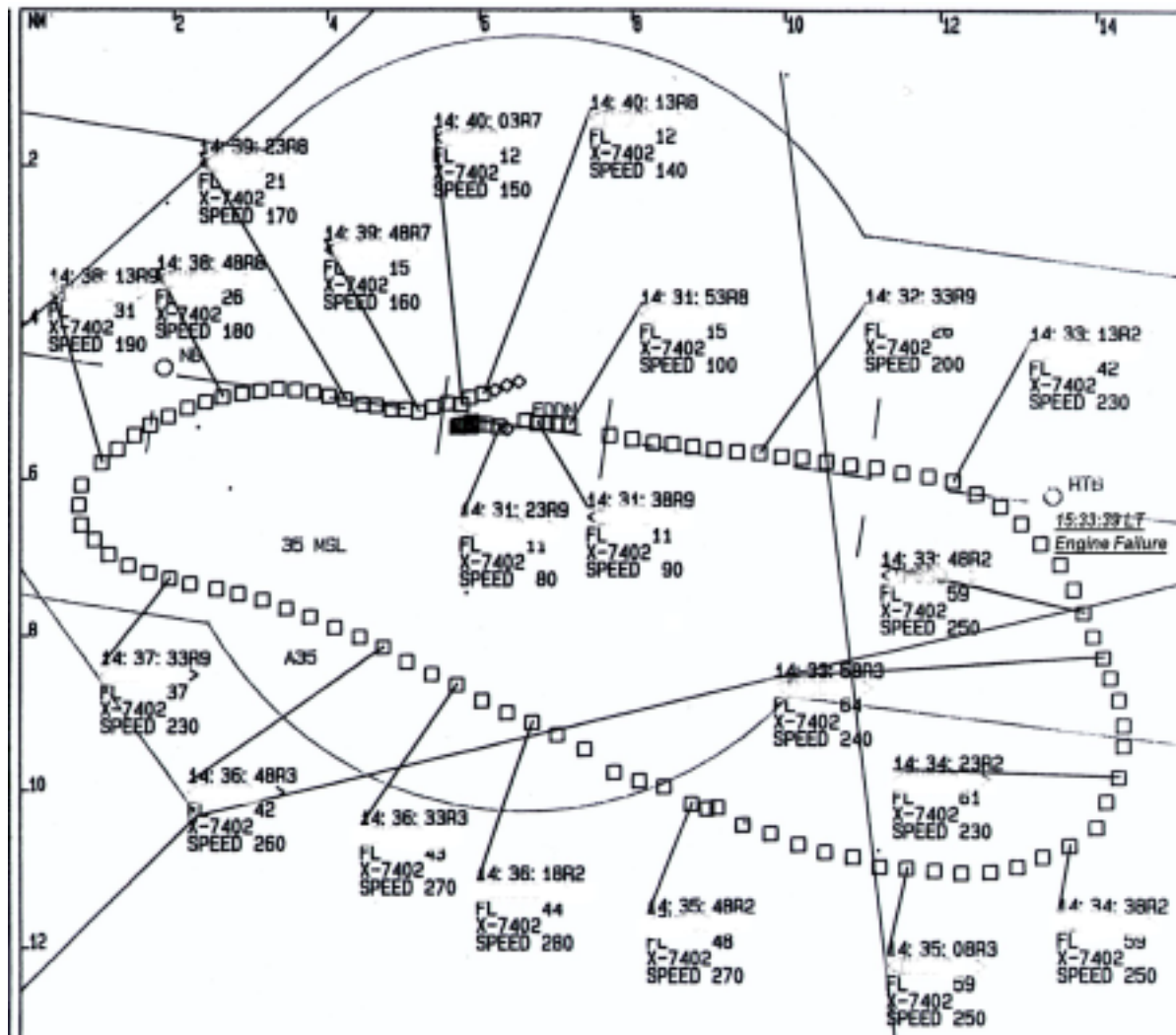

The Learjet descended below the 3° glide path for an instrument approach. The sudden speeding up of the right engine occurred almost simultaneously with the reduction of the descent rate. The airplane started to deviate from the extended center line to the left. Approximately 10 seconds later the pilot commanded "Flaps 20" in Italian language, the engine power was slightly reduced for a short time. The instruction to reduce the flap setting was confirmed by the second pilot with "Flaps 20", but obviously was not carried out immediately. The short command "Do it" was following. The descent rate was reduced to almost level flight. Simultaneously the engine was speeded up again to take-off power. The height increased to approximately 30 to 50 meters above ground, the engine power was slightly reduced for a short time and thereafter increased again. The flight behavior of the Learjet showed that after the retraction of the flaps to 20° the airspeed was permanently quite close to stall speed. In addition to the low airspeed and the flight configuration changes the asymmetric fuelling of the tip tanks had presumably contributed to the flight behavior observed during the last 30 seconds before the crash.

Until mid 2 000 the pilot-in-command had flown a Sabreliner in Argentina. Following his immigration to Italy he received the Italian citizenship and an employment as a pilot on the Learjet 35A. The transition training on the type was provided without simulator assistance by the owner of the airplane who in addition holds a flight instructor rating. The flight training (type rating) started on 13.10.2000 and was completed on 04.12.2000 with 22:26 flight hours. On 23.01.2001, after further 06:35 flight hours, he passed the skill test for obtaining the airline transport pilot license; the test consisted of a three hours' check flight with the Italian aviation authority. Thereafter he accumulated 25:43 hours as a pilot-in-command on the Learjet up to the day of the accident. The total flight hours on the type up to the accident day were logged with 54:44 hours including the transition training on the Learjet. The total flight experience on airplanes was 2 641 flight hours. No pilots' logbook was found in the wreckage. The data had been transmitted by the airplane owner.

Flight Guidance and Engine Instruments

The flight guidance and engine instruments brought from the accident site for further investigations were inspected and evaluated as far as possible. Most instruments were found to be destroyed or damaged too severely as to allow a safe evaluation of the indications. Since the cockpit crashed on the ground and the trees obliquely and in an inverted flight attitude, hardly any shock marks were detectable on the instrument scales. The pointers were

in part freely movable, heavily bent or the control bars were not in their bearings anymore. Thus the displays were not representative. The findings made on the instruments directly at the accident site must be classified as more valid than the result of the evaluation later on at Braunschweig.

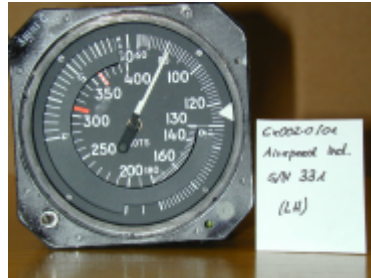

(Speed/Mach Meters)



(Artificial Horizons as found at the accident site)

Power Plant Probes



Left engine had stopped before the impact



Right engine had been running at high speed



Engine - Engine Instruments



Right Engine ↑

The investigation of the jet engines had shown that 3 mounts for the attachment of the tree post blade roots and 4 blades of the high pressure turbine (HPT) of the left power plant were missing. All other blades of the turbine were damaged on their leading edges and tips. The turbine blades which had separated were found within the turbine section. The shroud housing of the high pressure turbine was partially damaged. The broken mounts and turbine blades, however, had been contained in the housing.

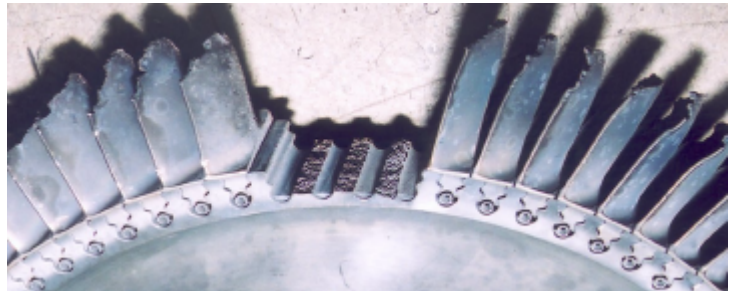

*left engine: High Pressure Turbine Disk(HPT)
Missing Tree Posts and Blades*

The technical material investigation revealed that intergranular cracking on the turbine disc had led to the loss of three mounts. In the cracking area there were further cracks proceeding from outside as well as fractured carbides with starting cracks in the within the material. The mounts adjacent to the cracking area also showed starting cracks in both waists. The material resistance (service life) against the combination of cyclical stress by speeding up and speeding down (cycles), creep stress and hot gas corrosions during the operation obviously had deteriorated.

On the right power plant further investigations were not carried out as the damage found after the accident had been caused by the impact.

Engine Maintenance

During the evaluation of the technical documentation of the engine SN 89244 it was found that the maximum of 5200 Cycles (CSN) prescribed in the service bulletin TFE731-72-3001, had been exceeded by 157 cycles.

Additional research revealed that prior to the installation into the engine SN 89224 the turbine disk had been installed in the engine SN 89508. At that period of time, the counting of cycles did not comply with the manufacturer`s instruction so that 3965 cycles had not been registered. When it was installed into the engine SN 89224 in February 1998 the high pressure turbine disk had already accumulated 6582 cycles. Together with the 2731 cycles accumulated meanwhile this resulted in a total of 9313 cycles at the moment of accident, i.e. 4113 cycles more than the allowable service life.

For the last operator and the various maintenance organizations it was not possible to find out the error on the basis of the recordings of the life limit card of the high pressure turbine disk.

The right engine which had been running up to the impact had accumulated a total of 6802 hours (TSN). During a spectrum oil analysis on 23.10.2000, a small amount of heat-treated steel had been found in the filter of the right engine. Thus an AGB-Inspection was performed on 07.02.2001 by a maintenance organization at Nuernberg. The front and rear bearings of the drive shaft of the starter/generator were removed and replaced by new ones.

Airplane Maintenance

According to the entries in the Technical Log Book the aircraft had a total flight time of 7275 hours with 7275 take-offs and landings up to 07.02.2001. The latest mass and balance report including the corresponding equipment list is dated 05.12.1999.

3. Conclusions

3.1 Findings

- The airplane was certificated properly.
- It was ferried to Nürnberg for the repair of the right jet power plant.
- Two pilots and a technician of the operator were aboard the airplane.
- During the checks prior to the starting of engines an uneven filling condition of the fuel tip tanks was noticed.
- The pilots were licensed properly and were allowed to perform the flight.
- The pilot in command only had poor experiences on the airplane type.
- During the initial climb, following the take-off for the return flight to Rome, the left engine failed.
- The pilot decided to immediately return to Nürnberg and declared an emergency.
- The prevailing weather were visual conditions with visibilities of more than 10 km, cloud bases not below 5000 feet and moderate wind.
- Failures or malfunctions of the airport approach aids had not been found.
- After the failure of the engine the control tower in Nürnberg transferred the airplane for a short period of time to the departure control center Nürnberg Radar). On this frequency the pilot again declared the emergency before he was instructed to contact Nürnberg tower again.
- Up to the final approach the approach was obviously without any problems.
- With the reduction of the engine power to flight idle, the flaps were set to 40 degrees (full flaps). After the reduction of the airspeed the remaining right engine was set to full power.
- The pilot in command ordered "flaps 20".
- Witnesses observed the airplane Dutch-rolling left and right at a low height.
- In short final the airplane suddenly deviated from the extended center line to the north
- Immediately afterwards the airplane stalled to the left and crashed into a forest in an almost inverted position.
- The airplane was destroyed by the impact and the impact fire.
- The occupants of the airplane were killed during the impact
- The airport fire service who had been alerted already during the approach of the Learjet was in standby position and arrived at the accident site approx. four minutes later and extinguished the fire in a short time.

- The flaps on the wreckage were in a position between 16 and 20 °. The flap lever in the cockpit was set to 20 °.
- The rudder trim was observed to be in a centered position.
- The uncommanded in-flight shutdown of the left engine was a result of intergranular fractures on the high pressure turbine disk having led to the loss of three blade retention posts with four turbine blades.
- Prior to the installation into the power plant TFE731-2-2B, SN 89224, the high pressure turbine disk had been installed in the power plant SN 89508.
- During the period of time when it had been installed in the power plant SN 89508, the cycles had not been counted in accordance with the Service Bulletin TFE731-72-3001, thus 3956 cycles had not been registered.
- When it was installed into the power plant SN 89224, the high pressure turbine disk had already accumulated 6582 cycles since new and thus had exceeded the allowable maximum of 5200 cycles.
- Between the moment of installation into power plant SN 89224 and the accident 2731 cycles have been counted in addition so that the allowable life limit of the high pressure turbine disk had been exceeded by 4113 cycles.
- For the last operator and the various maintenance facilities it was not possible to find out the error on basis of the recordings of the life limit card of the high pressure turbine disk.

3.2 Causes

The accident was caused by an in-flight failure of the left power plant appr. 3 minutes after take-off and an inadequate conduct of the subsequent single-engine landing procedure so that in short final the airplane stalled and crashed from low height.

The failure of the left engine was caused by intergranular fractures of retention posts on the high pressure turbine disk. As a result of incorrect service life recordings the maximum number of cycles had considerably been exceeded.

4. Safety Recommendations

None

5. Appendices

Radar track – ICAO map 1:500 000
Events – Approach to final RWY 10 EDDN

Braunschweig, February 7, 2003

Bundesstelle für Flugunfalluntersuchung
By order

Christian-Heinz Schuberdt
Investigator in Charge

The following employees have participated in the investigation:

Operations	Christian-Heinz Schuberdt
	Hector Casanova, NTSB
Flight Data Recorder	Axel Thiel
Power Plant	Juergen Dorner-Mueller
	David Keenan, NTSB
Radar Plots	George Blau
Air Traffic Control	Hans-Gunter Peters
Airplane Maintenance	Klaus Friedrich
Instruments	Uwe Pitz/Uwe Berndt

