

FINAL REPORT

AAIU Synoptic Report No: 2009-018

State File No: IRL00908014

Published: 23/09/09

In accordance with the provisions of SI 205 of 1997, the Chief Inspector of Air Accidents, on 20 March 2008, appointed Mr. Frank Russell as the Investigator-in-Charge to carry out a Field Investigation into this Accident and prepare a Synoptic Report.

Aircraft Type and Registration:	Agusta Westland A109E, EI-SBM
No. and Type of Engines:	2 x Pratt and Whitney PW 206 C
Aircraft Serial Number:	11174
Year of Manufacture:	2004
Date and Time (UTC):	20 March 2008 @ approximately 15.40 hrs
Location:	Lagore, Dunshaughlin, Co. Meath
Type of Flight:	Private Category
Persons on Board:	Pilot - 1
Injuries:	Pilot - Serious
Nature of Damage:	Substantially damaged
Commander's Licence:	Commercial Pilot Licence (H)
Commander's Details:	Male, aged 41 years
Commander's Flying Experience:	2,421 hours, of which 1,500 were on type
Notification:	ATC Station Manager, Dublin Airport
Information Source:	AAIU Field Investigation AAIU Accident Report Form submitted by Pilot

SYNOPSIS

The Pilot, the sole occupant of EI-SBM, was on a flight from Celtic Heliport, Knocksedan, Co Dublin to Weston Airport, Co. Kildare. En route, the Pilot advised Air Traffic Control (ATC) that he was approaching Dunshaughlin. Shortly thereafter, he informed ATC that he had a problem and then, almost immediately, reported that he would have to make an emergency landing and made a "MAYDAY" call. This was the Pilot's final transmission to ATC.

The helicopter landed heavily on soft ground and rolled over onto its left hand side. The helicopter was substantially damaged and the Pilot suffered serious back injuries. During the initial AAIU Investigation at the accident site, some cleaning cloth material was found entangled on the long tail rotor drive-shaft, between the first and second bearing (first bearing facing FWD).

FINAL REPORT

It was also found that the drive-shaft had completely severed just forward of the second bearing, thus cutting off the vital drive to the tail rotor gearbox. The Investigation concluded that the cloth induced out-of-balance forces on the shaft, causing the drive-shaft to fail. There was no fire.

1. FACTUAL INFORMATION

1.1 History of the Flight

EI-SBM lifted off from Celtic Heliport at Knocksedan, at approximately 15.32 hrs on 20 March 2008, having been cleared by Dublin ATC for a Special Visual Flight Rules (SVFR) flight to Weston Airport. The Pilot was instructed by ATC to “*route via the Dublin VOR, Ashbourne and Dunshaughlin, not above 1,000 ft QNH and to squawk 0433¹*”. En route, the Pilot advised ATC that he was approaching Dunshaughlin, which is at the Dublin Control Zone boundary. Shortly thereafter he advised ATC that ‘*I seem to have a bit of a problem here*’ and then almost immediately reported that he would have to make an emergency landing and transmitted a “MAYDAY” call. He made no further calls to ATC, although ATC called him back without reply.

In his interviews with the Investigation, the Pilot recalled that he was cruising at approximately 120 kts at 800 ft, with the Autopilot (AP) engaged; the wind from the South West (SW) was gusting 30-35 kts with 6-8 km visibility. Approaching Dunshaughlin, he heard a loud bang from the rear of the helicopter, at which point the nose pitched up and yawed dramatically to the right. The Pilot stated that as a result of the event there was an extremely violent release of energy and all the movements of the helicopter after the event were extremely violent in nature. He immediately disengaged the AP and applied full left pedal to counteract the yaw, but this had no effect. Dublin Radar returns show that the helicopter also briefly climbed to 1,000 ft about this time. The Pilot believed that he had lost tail rotor control, so he lowered the collective pitch lever to determine if the yaw rate would reduce, and this action, in turn, also reduced his airspeed. It was at this point in time that Dublin ATC queried EI-SBM’s change in direction to starboard (the opposite to his intended route to Weston) and the Pilot responded, after a brief delay, with the “MAYDAY” call.

The Pilot realised that he was drifting towards Dunshaughlin, his cyclic stick control appeared to be very limited, so he elected to increase the power in order to use the torque of the helicopter to keep it clear of the built up areas of Dunshaughlin. Once clear, the Pilot stated that he entered into an autorotation, shut down both engines using the engine power switches and lowered the undercarriage. He recalled that the helicopter was “*spinning at quite a rate*”, so much so that as he leaned forward to lower the undercarriage lever, the centrifugal force kept pushing him back into his seat.

Normal pilot orientation was not now possible, outside references were a blur, he recalled. So, he focused on the instruments in the cockpit, particularly the artificial horizon (AH), the Radio Altimeter (RADALT), which he remembered going through 280-250 ft, as he went down. The airspeed indicator (ASI) was of no use to him as the helicopter was spinning. When the RADALT was at 50 ft he resolved to flare the helicopter and pull as much collective (pitch) as possible.

¹ ATC Transponder setting

FINAL REPORT

The Pilot's next memory was lying on the ground some 10 to 15 feet from the helicopter, with rain falling on his face. He could see the helicopter on its side but he had no memory of the ground impact or how he had extricated himself from the helicopter.

The accident occurred at approximately 15.40 hrs. Approximately 54 seconds elapsed from the time the Pilot heard the loud bang to ground impact. The Pilot subsequently stated that there were no abnormal vibrations or other indications of anything amiss before the initial bang.

Due to the complete inaccessibility of the crash site to ambulances or any wheeled vehicles (a bridge-less river surrounded the boggy site), the Pilot was airlifted to Our Lady of Lourdes Hospital in Drogheda by the Irish Coastguard Helicopter, which had been alerted by Dublin ATC. Witnesses on the ground provided valuable directional assistance via mobile phones to ATC who relayed it, in turn, to the Coastguard Helicopter. Thus, the Helicopter lost no time in locating the isolated accident site, which was less than a mile from the centre of Dunshaughlin. The Pilot suffered serious back injuries.

1.1.1 Witness Statements

1.1.1.1 Witness No. 1

The first witness was in the back sitting room of his house on Lagore Road, Dunshaughlin, which faces out onto open fields, including the field of the accident site. He recalled that he *"saw the helicopter through the window manoeuvring away from our estate, saw it turning around, kind of hovered in the air, up, down, nose up, nose down but always going down"*. He called his wife, *"it started to spin full circle, nose up nose down, as it spun around. It all happened within seconds, the helicopter was struggling to stay up in the air, going nose up nose down and spinning, then it went out of sight behind a wall, heard the ground impact. I dialled 999 and described to the rescue services how to access the crash site and then went there. I found the Pilot outside the helicopter; he was conscious but clearly shocked. He kept asking where he was? The Pilot's phone, which was in the cabin, kept ringing. This was retrieved and answered by another witness. (In all probability this was Dublin ATC trying to contact the Pilot). I and the two other witnesses kept talking to the Pilot to try keeping him alert, his eyes were dilating, as we awaited the paramedics. The Coastguard helicopter came and landed well away from the crashed helicopter, as the immediate ground was soft and soggy. The Pilot was airlifted from the site shortly after 5 o'clock. As well as the helicopter spinning nose up nose down, I recall that there was no sound except from the rotor propellers, it was silent...eerie. There was strong winds and heavy drizzle."*

1.1.1.2 Witness No. 2

The second witness was looking out her kitchen window from her parent's house, also on Lagore Road, Dunshaughlin. *"I saw the helicopter nose down, it started spinning, saw it spinning fast, and I saw it hit the ground, I heard nothing but I knew it was bad. I pulled on wellies and ran to the site. When I arrived, I saw the rotor blades embedded into the ground. The helicopter was on its side with the Pilot standing beside it. The Pilot was going on about his phone, I retrieved it from the helicopter cabin, shortly after he collapsed on the ground and became motionless. He was complaining of neck and back pain. I saw the left door of the cabin open, I thought that the Pilot may have jumped out that way."*

FINAL REPORT

1.1.1.3 Witness No. 3

The third witness, who lives on the farm just across the river from the accident site, was standing beside a large green shed, observing the helicopter flying towards Dunshaughlin. *“The aircraft looped sharply to the right, half straightened out, kind of going backwards, spinning, no noise, then disappeared from my view behind some trees. There was a crunching noise, perhaps breaking propellers. I jumped through the river, and was the first person on scene. The Pilot was lying outside, perhaps he got out through the top door? I heard a mobile phone ringing somewhere. I rang 999 on my personal phone and awaited the rescue services, there was a smell of fuel but the engines were quiet before the landing.”*

1.1.1.4 Pilot Interviews

The Pilot was interviewed on two occasions by the Investigation. Both interviews were made voluntarily. The first interview was conducted in the hospital on the evening of the 21 March 2008, the day after the accident and the second was conducted in his residence on the 30 April 2008. The Pilot's accounts of the events leading up to and during the accident sequence, as contained in Section 1.1, History of the Flight, showed remarkable recall and consistency. However, there was one crucial difference between the two interviews. The Pilot was asked by the Investigation, if it was normal to open the cowling that covers the tail rotor drive-shaft during the pre-flight check (*as this is part of the Pilot's Daily Pre-flight Check*). In the first interview he responded that it was not normal to open the cowling and that he would never do so, whereas in a statement during his second interview he said that he did open the cowling the evening prior to the accident.

The Investigation recognises that during the first interview the Pilot was under the influence of significant pain killing medication.

1.2 Meteorological Information

The Dublin METAR (aviation weather report) Weather at 15.30 hrs UTC on 20th March was:

Wind:	270/22 kts,
Visibility	4,000m, Light Rain and Drizzle
Cloud	SCT 600' SCT 1,000', BKN 1,400'
Temp	10°C
Dewpoint	9°C
QNH	1008 hPa
Trend	TEMPO Cloud BKN 800'.

1.3 Additional Pilot Information

The Pilot qualified for the Agusta Westland A109 Type Rating in July 2004. This involved extensive ground school and flying training and examination on the helicopter itself. There was no Type Simulator available to the Pilot at that time in Europe. The first A109 simulator was certified for operational use by the Italian Civil Aviation Authority (ENAC), in June 2006.

The Pilot completed an A109E (Power) Course in July 2006 and an A109S (Grand) Course in July 2006. Up to the date of the accident the Pilot had accumulated approximately 1,500 hours flying on the A109 helicopter. He had not flown an A109 simulator.

FINAL REPORT

1.4 Recent Maintenance History

The Pilot flew EI-SBM from its base at Weston Airport to the Celtic Helicopters maintenance facility at Knocksedan, near Dublin Airport, on 4 February 2008. Here, the Standard Inspection Programme (a 12 Month/300 hour Inspection) per the Agusta Westland Maintenance Manual, was commenced and completed one month later, on 5 March 2008.

On the 5 March 2008, two post maintenance air tests were flown by the Pilot. These were followed by a ferry flight back to Weston, where the helicopter resumed normal private operations on the 6 March 2008. Over a period of 12 days until the 20 March 2008, EI-SBM undertook sixty flights, including the accident flight, all of which were flown by the Pilot. The helicopter's Technical Log records that the Pilot signed off on the Daily Inspection on each of these operational days. From the evening of the 5 March to the 20 March 2008, inclusive, the helicopter was hangared at Weston Airport where there is no maintenance facility available to the Operator. For this reason, maintenance was outsourced and performed in the Maintenance Organisation at Knocksedan.

Before the first flight of each day, a pilot is obliged to carry out a routine Pilot's Daily Pre-flight Check, per the A109E Rotorcraft Flight Manual. This requires, inter alia, under First Flight of the Day Area 4 & 5, 'Tail rotor long drive-shaft bearings', that the bearings be inspected to '*Check condition verifying no mark slippage*'. This particular check necessitates the person performing it (normally the pilot) to open the fairing (or "spine cover", as it is sometimes called) that covers the long tail rotor drive-shaft. In a statement during his second interview with the Investigation the Pilot said that he had carried out this check on the 18 March 2008, prior to his departure to Ashford Castle and, again, on the evening of the 19 March 2008, as he had an early morning departure to Dublin Airport the next day, and did not want any undue delay. He stated that he did not see any cloth material in either of those two Pre-Flight Checks. In the event, this early flight on the 20 March 2008 was cancelled so the Pilot flew to the Celtic Helicopters facility. Here by prior arrangement, new R/H and L/H engine fire bottles were installed (these were not available at the time of the earlier 12 Month Inspection and "loaner" fire bottles were used in the interim). In addition, a Tail Rotor Blade crack inspection was carried out in compliance with an Airworthiness Directive (AD). In their statement to the Investigation, the maintenance organisation said that they only carried out the two required maintenance tasks and washed the helicopter that morning with a hose, brush and soap. They stated that they did not open the tail rotor long tail rotor drive-shaft fairing, as there was no technical reason to do so. The Investigation notes that the fire bottles are enclosed under the P20A access panel (**Appendix A**). However, it is also noted that the A109E Maintenance Manual requires under Section 26-21-8, Removal/Installation of No. 1/No. 2 bottles, that access panel P21 be removed. Removal of the P21 access panel requires that the tail rotor drive-shaft cover be opened.

On completion of these routine jobs, the Pilot planned to ferry the helicopter back to Weston Airport on the afternoon of the 20 March 2008.

FINAL REPORT

1.5 Tail Rotor Drive –Technical Description

Power is transmitted from a drive on the main transmission to the tail rotor through three in-line shafts and a 90-degree tail gearbox. The 90-degree tail gearbox provides a 90° change in the direction of drive and a 2.8 to 1 speed reduction between the input shaft and the output shaft, on which the tail rotor is mounted.

The tail rotor counters the torque of the main rotor, thus enabling directional control of the helicopter in both the engine-on and engine-off conditions. The design and installation of the drive-shaft, which is covered and runs along the top centre of the tail boom, allows for a certain flexibility in longitudinal movement of the complete shaft and normal deflections of the tail-boom in flight. The tail rotor drive-shaft nominally turns at 5,872 RPM, which corresponds to 100% free turbine RPM. The tail rotor drive system is shown in **Appendix B, (Figure B1)**.

The tail rotor drive-shaft consists of three sections, namely the Forward, Middle and the Long sections. These sections are made from aluminium alloy tubes and are interconnected by Thomas Couplings and are supported by Hanger Assemblies that are secured to the tail-boom structure. Five Hanger Assemblies support the Long section. The Hanger Assemblies are effectively floating support bearings.

The Middle and Long sections of the tail rotor drive-shaft are covered by three separate fairings or covers. The forward two fairing are secured by fasteners and are removed by opening the fasteners. The first of these fairings, the Forward Fairing (working from front to rear) covers the front end of the Middle tail rotor drive-shaft. The engine fire extinguisher bottles are also located under this fairing. This fairing overlaps the next fairing, the Middle Fairing, which means that the forward fairing can be removed without removal of the Middle Fairing. The Middle Fairing covers the aft section of the Middle tail rotor drive-shaft, and the Thomas Coupling between the Middle and Long drive-shaft.

The location of these fairings is shown in **Appendix C, (Photo No. 1)**. The aft end of the Middle Section Fairing contains a hinged inspection cover. When opened, this inspection cover gives access to the Thomas Coupling, without the necessity of removing the entire fairing. **Appendix C, (Photo No. 2)** shows the access to the Thomas Coupling with this panel in the open position. The Long shaft is covered with one long fairing, which is hinged on the RH side of the tail-boom and is secured by fasteners to a raised lip on the LH side of the tail-boom. The Long Shaft Fairing overlaps the Middle Fairing, but is itself overlapped by the hinged Inspection Panel of the Middle Fairing (Thomas Coupling Cover). Thus to open the Long Shaft Fairing, the hinged Inspection Panel must first be opened. Opening the Long Shaft Fairing does not require that the Middle Fairing be removed. The Long Section Fairing is shown in the open position in **Appendix C, (Photo No. 3)**.

1.6 Radar/GPS Data

1.6.1 General

The track flown by the helicopter, from Knocksedan to Dunshaughlin, is shown in **Appendix D, (Figure D1)** using the data from the Global Positioning System (GPS) receiver recovered from the helicopter. This data was compared to that taken from Dublin ATC Secondary Surveillance Radar (SSR). The two datasets were in agreement, notwithstanding the lower positional accuracy of the radar data. Radar did record the helicopter momentarily climbing to 1,000 ft. The GPS data was of significant assistance to the Investigation.

FINAL REPORT

The GPS data was reviewed using the estimated wind, as provided by Met Éireann and the final 54 seconds of the Helicopter's flight is re-constructed in **Appendix D, (Figure D2)**. This reconstruction represents an idealised, calculated approximation of the helicopter's final moments. By design the GPS only tracks (and records) the path followed by the helicopter.

The Investigation recognises that the helicopter was spinning during its final descent, however this spinning motion was not (and could not be) recorded by the GPS. Consequently, the plot produced from the GPS data (**Figure D2**) describes the geographic path followed by the helicopter (in reality by the GPS receiver) but does not indicate the complex rotating/oscillating motion, which the helicopter undoubtedly exhibited.

1.6.2 GPS Information

The helicopter is recorded on GPS cruising on a constant near westerly heading at an estimated IAS of 120 kts towards Dunshaughlin at 800 ft above ground level (agl). Between approximately 54 to 49 seconds from impact the helicopter commenced a gentle right-hand turn and the speed decreased towards 91 kts. The helicopter continued in this gentle turn at reducing calculated airspeeds of 86 kts (11 seconds from commencement of the turn), 81 kts (17 seconds), 74 kts (24 seconds) and 63 kts (30 seconds). At 35 seconds the calculated airspeed had reduced to 56 kts, so at some time between 30 seconds and 35 seconds (half a minute) after the initial course change the calculated airspeed dropped below 60 kts. In the remaining 24 seconds, the rate of turn increases further to the right, as does the speed decay down to a minimum estimated IAS of 7/8 kts.

1.7 Flight Simulator Training Device (STD) Tests

1.7.1 General

The Investigation conducted tail rotor failure tests on an A109 (Power) Flight Simulator Training Device, at the Agusta Westland Training Academy, Sesto Calende, near Milan. This simulator was certified, and the training syllabus approved, by the Joint Aviation Authority (JAA) - (JAR – STD – 1H Level D) in June 2006, through the Italian Civil Aviation Authority (ENAC). The exercises performed on the simulator are recognized by ENAC as valid flight activity for the type rating approval.

The data on which the STD was modelled was derived from the manufacturer's A109E Flight Test and Certification Programme. The STD is governed by a mathematical model and helicopter aerodynamic characteristics, which are determined through flight-testing on an instrumented aircraft and verification by experimental test pilots. These tests show, inter alia, that the vertical fin of the A109E produces an anti-torque component which is a function of the forward speed and which, combined with the cyclic control, permits directional control of the helicopter within a certain speed envelope.

1.7.2 STD Exercises

The AAIU Chief Inspector of Air Accidents flew the simulator; the Agusta Westland Senior Flight Instructor provided flight instruction and an Agusta Westland Flight Instructor provided the programming. The entire test was monitored by the Investigator-In-Charge (IIC) of EI-SBM.

FINAL REPORT

It is obvious that it is not possible to demonstrate an actual tail rotor drive failure in flight and that the use of the STD is considered to be the most appropriate and safest method to demonstrate this failure. Further, in discussions with both Flight Instructors, it was their belief that the simulator performed very closely to that of the real helicopter and that the simulated tail rotor drive failure would be very representative of an actual live failure.

The main purpose of this simulator test was to:

- (1) Determine directional controllability of the helicopter following a tail rotor drive failure.
- (2) Following loss of directional control from a tail rotor drive failure, initiate recovery technique to regain directional control.
- (3) Following loss of tail rotor drive, carry out full autorotation for a two engine out landing.

1.7.3 Test 1. Determine directional controllability of the helicopter following a tail rotor drive failure.

1.7.3.1 Pre-failure conditions

Visual Flight Rules (VFR) Straight and Level (S/L) at 1,500 ft with an Indicated Airspeed (IAS) of 120 kts.

1.7.3.2 The Exercise

Following the unannounced² tail rotor drive failure no appreciative sensation was experienced other than a slight tendency for the helicopter to roll/turn and climb to the right. Correction was achieved with a slight input of left and forward cyclic. Directional control was maintained and flight was continued. As further power was applied, tendency to roll/turn right increased. As power was reduced tendency to roll/turn right was reduced. The helicopter was then decelerated slowly from 120 kts back to 70 kts. As the IAS reduced, the tendency to rotate right increased in proportion to the loss of speed and required increase input of left and forward cyclic. Directional control was fully maintained down to 70 kts with full deflection of left cyclic with a forward input. Heading and height were maintained with the helicopter crabbing to the left with right yaw. As the helicopter decelerated further down to 60 kts, the maximum corrective control inputs were insufficient to stop the rotation to the right. IAS decayed dramatically from 60 kts down to 40 kts as the helicopter entered a violent rotation to the right with a marked nose down attitude. As IAS decreased further down to 20/0 kts the helicopter had a tendency to pitch nose up/down while spiralling out of control until impact. The rate of descent (ROD) during this spiral manoeuvre was recorded at up to 3,000 ft per minute.

1.7.3.3 Comment

The test demonstrated that while in cruise flight (in this case 120 kts) there was no particular aerodynamic sensation of the tail rotor drive actually failing other than the fact that the rudder pedals became inoperative. Directional control could be maintained safely down to 70 kts where appropriate corrective inputs were made to stop the tendency for helicopter to rotate to the right. Directional control could not be maintained below 60 kts.

² Unannounced: Is a recognised term used in aviation safety training where the Pilot Flying is given an emergency situation without warning by the Instructor.

FINAL REPORT

1.7.4 Test 2. Following loss of directional control from a tail rotor drive failure, initiate recovery technique to regain directional control.

1.7.4.1 Pre-failure conditions

Visual Flight Rules (VFR) Straight and Level (S/L) at 1,500 ft with an Indicated Airspeed (IAS) of 115 kts.

1.7.4.2 The Exercise

Following the unannounced tail rotor drive failure, directional control was maintained and the flight continued. IAS was then gradually reduced while still maintaining directional control down to 70 kts. As IAS decreased further from 60 kts down directional control was lost in a right rotation. Recovery was then initiated whereby full engine-on autorotation (zero power/collective) was set; rotation to the right stopped and the helicopter was dived in order to increase airspeed. As IAS increased through 80/90 kts, the helicopter was taken out of autorotation (increased power/collective), ROD was reduced to S/L flight whilst maintaining IAS of 90 kts. Directional control was fully regained. Height loss from loss of control to S/L recovery was approximately 700 ft.

1.7.4.3 Comment

The test demonstrated that following loss of directional control as a result of tail rotor drive failure, directional control could be regained if the appropriate corrective recovery technique was performed and that sufficient height (in excess of 1,000 ft) was available.

1.7.5 Test 3. Following loss of tail rotor drive, carry out full autorotation for a two engine out landing.

1.7.5.1 Pre-failure conditions

Visual Flight Rules (VFR) Straight and Level (S/L) at 1,500 ft with an Indicated Airspeed (IAS) of 115 kts.

1.7.5.2 The Exercise

Following the unannounced tail rotor drive failure, directional control was maintained and the flight continued towards a nearby runway. Undercarriage was selected down and the helicopter was positioned for an autorotation onto the main runway. Once established in autorotation, both engines were shut down; flare was initiated at 150 ft agl and a full engine-off run-on autorotation was performed onto the runway.

1.7.5.3 Comment

This test demonstrated that following loss of tail rotor drive in the cruise, directional control could be maintained and the helicopter could be flown under control to a site suitable for an engine-off, run-on, autorotation landing.

1.8 Technical Examination

At the accident site the Investigation found that the helicopter had fallen over onto its LH side in the boggy ground. All four main rotor blades had suffered heavy ground impact and had failed and shattered close to the hub. However, the two blades of the tail-rotor showed little damage.

FINAL REPORT

In particular, one blade was virtually unmarked. This suggested that the tail-rotor, which is located on the LH side of the helicopter, was not rotating at impact. At this point, all the fairings over the tail rotor drive-shaft system were found to be closed and secured. On inspection of the tail-rotor drive train (the connecting shafts between the tail-rotor gearbox and the main gearbox) it was found that the long tail rotor drive-shaft, which is located under the hinged fairing on top of the tail boom, had failed. The point of failure was immediately forward of the No. 2 Hanger Assembly. A cloth, as described below, was found tightly wrapped around the forward segment of the broken Long shaft, at a point approximately 34 cm forward of the shaft fracture point, as shown in **Appendix C, (Photo No. 4)**. The splines on the forward end of this shaft section were still engaged in the Thomas Coupling at the forward end of the shaft, but it had moved rearwards slightly. The Investigation noted that the bearing core (inner rubber collar) of the No 1 Hanger Assembly had come out of the bearing, so that this bearing only partially restrained radial movement of the forward section of the failed shaft. The Investigation noted that the split pins and nuts located on the aft side of the support structure of the No 1 Hanger Assembly contained particles of material identical to the cloth. No such material was found forward of this point. The ends of the shaft at either side of the failure bore damage associated with rubbing contact after the failure.

The cloth was very tightly wrapped around the long tail rotor drive-shaft. It was compressed and measured 10 cms along the shaft. In addition, it was sodden with moisture when found. The cloth was subsequently unwound from the shaft, and was found to measure approximately 56 cms by 42 cms, and frayed at the edges. It weighed 72 grams when dry, and up to 225 grams when wetted as part of the ongoing Investigation. The cloth is shown in **Appendix C, (Photo No. 5)** after it was removed from the shaft.

The shaft was examined for any surface defects, or any marks that did not result from the presence of the cloth. None were found.

1.9 **Other Information**

- 1.9.1 On the 30th March 2008, ten days after the accident, the IAA notified the Investigation that they had received a report that a cloth and a tool were found in another Irish registered A109. It subsequently transpired that this tool was seen by a Pilot on the Main Gearbox (MGB) platform of his helicopter on the 18th March 2008. However, he did not report this sighting to anybody at that time. On the 1st April, the IAA and the Investigation visited this helicopter in Enniskillen and were shown where a cloth had been lodged behind the MGB and also the location where a torque wrench had been seen on the MGB platform. This torque wrench did not belong to the Enniskillen facility. The provenance of this torque wrench is in dispute and the matter has been referred to An Garda Síochána. Also found were two more cloths of similar material and size, which were left in pockets in the cockpit, and another in a container in the luggage compartment of this helicopter
- 1.9.2 Prior to this accident, the provision of cleaning cloths from the maintenance organisation's stores was based on a free issue policy. After the accident, a cleaning cloth control system was introduced, whereby new cloths were only issued by the stores on receipt of used cloths.
- 1.9.3 The Investigation noted that there is a requirement for tail rotor drive-shaft post Inspection Maintenance that states, "*During the initial 5 hours of operation of a new bearing, or after re-greasing, leaking of excess grease may occur. In such a case remove grease leaked out with a dry cloth. Thereafter, further grease leaks are evidence of malfunctioning; in such case bearing must be replaced*".

FINAL REPORT

This inspection was due after the bearings were greased on the annual inspection. The Investigation found no evidence that this inspection was performed by the maintenance organisation at any time between 6 March 2008 and the accident date. The performance of this inspection would have required that the fairing over the long tail rotor drive-shaft be opened.

- 1.9.4** There is a raised lip on the top of the tail boom, against which the Long Section Fairing closes. This lip is approximately 20 mm high. An aerodynamic Strake, approximately 100 mm high is located on the same side of the tail-boom. Both these items can be seen in **Appendix B, (Photo No. 3)**. A person of average height cannot see the top deck of the tail-boom, in the area under the driveshaft, because of these obstructions.

The Long Section Fairing is secured along its length by a piano hinge, on the RH side of the tail-boom. There are significant gaps along the line of the piano hinge. This is shown in **Appendix C, (Photo Nos. 6 and 7)**.

- 1.9.5** The Agusta Rotorcraft Flight Manual (RFM A109E), Emergency and Malfunction Procedures, Section 3, Drive System Failures (Tail Rotor Failure) outlines to pilots the procedure to identify and recover from tail rotor failure.
- 1.9.6** The Investigation notes that the UK Air Accident Investigation Branch (AAIB) published a Report (EW/C2006/10/04) into an accident in which the tail rotor assembly separated from an Agusta A109A while in the cruise, after being struck by a departing exhaust duct. This caused severe damage to both vertical stabilisers and the aft tailboom. This Report states that a degree of directional control was maintained following the loss of the tail rotor assembly.

1.10 Tests And Research

The failed ends of the shaft were subjected to metallurgical examination. However, this examination showed that the consequential damage to the fracture surfaces, caused by severe rubbing between the failed ends of the shaft, destroyed the original fracture features.

The Investigation reviewed the operational history of the Agusta Westland 109 fleet and did not discover any previous history of failure of the long tail rotor drive-shaft of the tail rotor drive system.

FINAL REPORT

2. ANALYSIS

2.1 General

The Investigation recognises that the loss of tail rotor drive is an extreme failure and would severely challenge any individual pilot confronted with such an event. The purpose of this analysis is twofold. The Technical Analysis seeks to determine why the tail rotor drive-shaft severed. The Operational Analysis seeks to understand the effects of the loss of the tail rotor drive and the recovery process.

2.2 Technical Analysis

The Investigation was hampered by the damage to the fracture surfaces on either side of the failed long tail rotor drive-shaft. This damage precluded any meaningful metallurgical examination of the fracture surfaces. Thus it was not possible to determine the failure mechanism by analysis of these surfaces.

In this version of the Agusta Westland A109, a one-piece Fairing covers the entire length of the long tail rotor drive-shaft. The Fairing is closely fitted to the shape of the Hanger Supports, with the result that there is only a small clearance between the Hanger Support and the inside of the Fairing. The Thomas Coupling is under the hinged Inspection Panel of the Middle Section Fairing. This Panel is also a close fit to the Coupling. The Investigation considers that the close fit would prevent any migration of a cloth, of the size found on the shaft, from the area forward of the Thomas Coupling, into the space where the cloth was subsequently found, as this would require the cloth to pass by the close-fitting Thomas Coupling and the No. 1 Hanger Assembly. Furthermore, the Thomas Coupling has exposed splines, nuts and bolts that would have caught fragments from a cloth passing through the coupling area. No evidence of any cloth fibres was found on the Thomas Coupling. No evidence of cloth fragments was found on the No. 2 Hanger Assembly or to the rear of this point. Thus the Investigation is satisfied that the cloth was originally left in the space between the No. 1 and No. 2 Hanger Assemblies, and did not migrate into this space from another location in the helicopter.

The Investigation noted that the two fire bottles were replaced on the morning of the accident. The maintenance organisation informed the Investigation that this was accomplished by removing only the Forward Fairing (P20A access panel) over the Middle tail rotor drive-shaft. The Investigation found that replacement of the fire bottles could be accomplished without removing any other fairings. However, this was not in compliance with the requirements of the Maintenance Manual.

The maintenance organisation further informed the Investigation that the only other maintenance action required on the helicopter that day was the accomplishment of an AD, which required an inspection for cracks on the type of tail rotor blades fitted to this helicopter. This inspection did not require any of the fairings on the tail rotor drive-shaft system to be opened. The Investigation also noted that the tail-boom was washed during this maintenance. This is normal as the tail-boom is exposed to combustion residue from the engine exhausts. This washing was accomplished with the aid of a hose connected to a standard water supply. The Investigation noted that there were significant slots along the piano hinge-line of the long tail rotor drive-shaft fairing. These slots could have facilitated water entry into the area of the Long shaft, and this is a possible explanation for the sodden state of the cloth, as found at the accident site.

FINAL REPORT

Considering that there was no history of failure of the tail rotor drive-shafts on the Agusta Westland A109 fleet, and the presence of a substantial cloth wrapped around the shaft, at a point adjacent to the failure, the Investigation determined that the presence of this cloth, around the shaft, and the consequential out-of-balance forces on the shaft, was the cause of the failure³. The mechanism of failure was that the cloth introduced an eccentric loading in the shaft, which resulted in cyclic radial loading of the shaft, causing it to fail due to metal fatigue.

The Investigation gave consideration to conducting dynamic tests on the shaft section in an effort to determine the out-of-balance effect induced by the cloth, and the resultant whirling forces on the shaft. This would have involved fitting the cloth to a complete shaft in an identical configuration to that found at the accident site, and loading the cloth with water to replicate the sodden state in which the cloth was found. In addition, the replication would have been further complicated by the nature of the deterioration of the bearing in the No 1 Hanger Assembly. In view of the number of variables, some of which were indeterminable, the Investigation concluded that it would not be possible in a test to accurately replicate the conditions to which the failed shaft was subjected.

Design information was supplied by the helicopter manufacturer, in the form of S-N⁴ data for the Aluminium Alloy 2024, the material used to manufacture the long tail rotor drive-shaft. Knowing the rotation speed of the shaft the Investigation was able to note points on the graph that effectively converted cycles into duration of shaft rotation. The modified graph is shown in **Appendix E, (Figure E1)**. Specifically, the graph shows the points corresponding to 6 minutes (35,232 cycles) of shaft rotation, 10 minutes (58,720 cycles) of shaft rotation (4 minutes ground running, plus 6 minutes flying, the probable running of EI-SBM on the day of the accident) and 25 hours flying (8.8 million cycles), which corresponds to the total flying of the helicopter since the annual inspection was completed. The manufacturer's data derives from tests conducted in laboratory conditions where all the variables were known. In the case of this accident, many of the variables are, unfortunately, unknown. The data from the graph suggests that the fatigue failure, due to shaft imbalance, was possible at any point in the period of 6 minutes to 25 hours (i.e. at any point between the last Annual Inspection and 6 minutes after take-off on the final flight). The data does not indicate at what time, in this period, the imbalance forces were initiated, or when the cloth became entangled in the shaft. However, the 25-hour value of 8.8 million cycles is very close to the asymptote value of 10^7 (10 million) cycles, where the fatigue resistance becomes infinite. While this data is not conclusive, it does suggest that the out-of-balance forces were present for less than 25 hours flying.

The foregoing is based on the premise that the vibrations experienced by the long tail rotor drive-shaft were at a frequency that corresponded directly to the shaft RPM.

³ Masses rotating at high speed, such as wheels and shafts, are required to be dynamically balanced to prevent out-of-balance rotating centrifugal forces that can result in vibration, or, ultimately, fatigue failure of the component or its support bearings. In the case of long flexible shafts, which are only supported at intermediate points, such as helicopter tail rotor drive-shafts, out-of-balance forces can deflect the axial line of the shaft so that the centre of gravity of the shaft is displaced from the axis of rotation. As a result, the out-of-balance forces are increased significantly, which in turn increases the deflection of the shaft. This compounding situation is known as shaft whirling, and imposes high cyclic loads on the shaft and its supports. Because of the high speed of rotation, the shaft experiences a high number of stress cycles, and this can lead to metal fatigue failure. It may be noted that, in such cases, the initial out-of-balance force may be quite small.

⁴ An S-N curve, also known as a Wöhler curve, is a graph of a failure-inducing cyclical stress (S) against the number of cycles (N) experienced by a component. The number of cycles to failure is plotted on a logarithmic X-axis and the stress on the Y-axis. It shows the number of cycles the component can withstand a given level of stress, before failure occurs.

FINAL REPORT

While this is probable, it is possible that the shaft vibrated at another frequency that was the result of its own natural frequency, which would have been altered by the presence of the cloth and the possible pre-failure deterioration of the No. 1 Hanger Assembly bearing.

It is also possible, prior to the failure of the tail rotor drive-shaft, that the cloth, or fragments of it, became entangled in the No. 1 Support Assembly bearing, which may have been a factor in the displacement of this bearing, as found subsequently.

Damage to the bearing precluded a definite conclusion on this issue. Any loss of the radial location of the shaft, due to deterioration of the bearing, would have made the shaft more susceptible to damage due to whirling forces.

The Investigation considered that there were a number of possibilities, from a purely technical standpoint, by which the cloth came to be within the tail-rotor drive-shaft area and subsequently caused the shaft to fail.

- The cloth was left on the shaft during the Annual Inspection completed 25 hours before the accident.
- The cloth was left on the shaft sometime between the 25 hr inspection and the start of the accident flight.
- The cloth was left on the shaft during the maintenance performed on the day of the accident.
- The cloth may have been left lying on top of the tail rotor boom, on the flat area below the shaft, at some time in the previous month. Flight turbulence or general manoeuvring may have then caused it to flip upwards and become entangled in the rotating shaft. It should be noted that the presence of the raised lip and the aerodynamic strake makes it difficult, if not impossible for a pilot, standing beside the tail boom during a daily inspection, to see a cloth lying on the boom. A person's view is dependent on his/her height and steps may be required to perform this inspection.
- It is possible that the cloth could have, at some stage in the previous 25 hours, become wrapped around the shaft but in a benign manner, i.e. reasonably evenly distributed around the shaft so as not to cause any significant imbalance. However, the tail boom was washed during the maintenance on the day of the accident. It is possible that the washing immediately prior to the accident flight resulted in significant water mass being added to the cloth, in an uneven manner, through the slots in the piano hinge. The uneven addition of the water may have been sufficient to upset the dynamic stability of the shaft and to initiate the cycling loads, which ultimately caused the failure. In this regard, it is significant that the Investigation found that the cloth could hold more than twice its own weight in water.

The Investigation has no doubt that the presence of the cloth, however and whenever it was introduced into the tail rotor drive shaft system, was the cause of the long tail rotor drive-shaft failure.

FINAL REPORT

From the information available to the Investigation, it has not been possible to absolutely determine, when and by whom the cloth was left in the area of the tail rotor drive-shaft. While it is known that cleaning cloths are widely used throughout the aviation industry, the Investigation considers that, as the helicopter was being maintained by only one maintenance organisation, the probability is that the cloth was inadvertently introduced at some stage during the maintenance cycle. The Investigation notes the absence of a cloth control procedure or system in the maintenance organisation prior to the accident. The maintenance organisation subsequently introduced such a procedure.

It is recognised that these cloths are widely used by technicians during maintenance and cleaning. In addition, pilots would also use cloths for general cleaning of the windscreen and other parts of the helicopter between flights.

The discovery of any maintenance cloths or tools on this or any aircraft is a matter of concern to the Investigation. Consequently, and in the interest of Flight Safety, a Safety Recommendation is directed to the IAA requesting that they review the control of tooling and loose articles used in the maintenance of aircraft.

2.3 Operational Analysis

The unprecedented and unexpected fracture of the tail rotor drive-shaft ended this short flight prematurely in circumstances that were mostly beyond the Pilot's training experience. While cruising at 800 ft just east of Dunshaughlin and below the scattered cloud base, the Pilot heard a loud bang from behind and he reported that the helicopter yawed to the right. As reported, he instinctively attempted to regain directional control by applying left pedal but this action was ineffective in the circumstances. Radar does record a height gain from 800 ft to 1,000 ft. This may have been associated with the fact there would have been an increased availability of power following loss of power drive to the tail rotor. The intentional turn away from Dunshaughlin (*Pilot reported that he was determined to avoid Dunshaughlin and he turned the helicopter away from this built-up area*) and the natural tendency to reduce power after hearing a loud bang from the rear) brought about a situation whereby airspeed decreased as the helicopter entered the gentle right turn.

However, subsequent simulator tests demonstrated that no rapid yaw to the right was experienced following tail rotor failure at 120 kts and directional control could be maintained once airspeed was kept above a minimum of 60 kts. When speed dropped below 60 kts, directional control was lost, the helicopter pitched nose down and entered a violent spiral. As speed decreased further the helicopter had a tendency to pitch nose-up/down as it spiralled uncontrollably.

As witnesses reported "*It all happened within seconds, the helicopter was struggling to stay up in the air, going nose up nose down and spinning*", and "*I saw the helicopter nose down, it started spinning, saw it spinning fast*", very much resembled that which was experienced by the Investigation during the simulator test.

Evidence derived from the GPS data and Radar data, shows that from its first change of direction East of Dunshaughlin to ground impact the elapsed time was approximately 54 seconds. For a period of between 30 – 35 seconds after the loss of the tail rotor the helicopter had sufficient airspeed to allow a degree of directional control to be maintained.

FINAL REPORT

The Investigation is therefore of the opinion that the helicopter did not enter an uncontrollable spiral immediately following loss of the tail rotor. Over a period of 30 seconds the helicopter decelerated down through 60 kts in a gentle right-hand turn. When the speed reduced below 60 kts directional control was lost and it entered an increasingly violent spiralling descent. Eyewitness observations of the final moments of the descent and the fact that the helicopter continued its violent spiral rotation, suggests to the Investigation that the helicopter did not achieve a full auto-rotative state.

It must be acknowledged that the Flight Simulator could not and did not, replicate the surprise factor and extreme centrifugal forces reported by the Pilot as the helicopter descended to earth. These centrifugal forces, in turn, would have added greatly to his control problems.

It is considered likely that following loss of control, the helicopter spiralled to earth, during which the Pilot shut down both engines and selected undercarriage down, as he descended.

The Pilot then reacted instinctively by flaring the helicopter at approximately 50 feet above the ground to cushion the landing. The Pilot had no recollection as to what happened next. However, his timely flaring of the helicopter and the soft boggy ground were enough to ensure his survival by his unaided, adrenalin driven exit from the cockpit to the relative safety of the ground where he collapsed.

The Investigation notes that the Pilot completed his approved conversion training on the Agusta Westland A109 two years before a Flight Simulator became available for general use in Europe. This meant that his training for certain emergencies could only be carried out on an actual helicopter, thus restricting the type of emergencies that could be practised.

Among the emergencies that were not possible to practice would have been tail rotor drive-shaft failure and it was this critical failure that the Pilot was confronted with for the first time in his career on the 20 March 2008. The exercises undertaken by the Investigation in the Flight Simulator highlighted very clearly what happens when the tail rotor drive-shaft fails and in a manner that the Emergency and Malfunction Procedures Section of the Agusta Westland A109 Flight Manual describes in words. Helicopter pilots are trained to respond instinctively and quickly to engine or airframe failures, as time is of the essence in such situations. However, such pilots can only respond to the degree to which they were previously trained.

A Safety Recommendations is therefore made to the European Aviation Safety Agency (EASA) in respect to the use of simulators for helicopter pilots.

3. **CONCLUSIONS**

(a) Findings

1. The Pilot was properly licensed and medically fit in accordance with Joint Aviation Authorities (JAA) requirements.
2. The Investigation found no evidence that the 5-hour inspection, required after the bearings were re-greased during the annual inspection, was carried out.

FINAL REPORT

3. The Investigation noted that the fire bottles on the helicopter were replaced by the maintenance organisation on the morning of the accident. This was accomplished by removing the P20A access panel only, while not removing access panel P21. The Investigation found that replacement of the fire bottles could be accomplished by removing P20A only. However, this was not in compliance with the requirements of the Maintenance Manual.
4. Weather conditions were adequate for the short SVFR flight to Weston Airport and were not a factor in this accident.
5. Air Traffic Control (ATC) communications were normal. The prompt alerting of the Irish Coastguard Helicopter by ATC and eyewitnesses assistance in pinpointing the accident site were critical in the speedy air evacuation of the Pilot to hospital.
6. Evidence derived from the GPS data shows that from its first change of direction East of Dunshaughlin to ground impact the elapsed time was approximately 54 seconds.
7. Simulator Flight Tests carried out to determine the likely reaction of the Agusta Westland A109 in circumstances similar to the subject event showed that, inter alia, directional control could be maintained safely down to 60 kts but that directional control could not be maintained below 60 kts. Below this speed there was a marked pitching motion of the nose and rapid movement in the yaw axis.
8. Another Simulator Flight Test confirmed that following loss of directional control as a result of tail rotor drive-shaft failure, directional control can be regained if the appropriate corrective recovery technique is applied and that sufficient height (in excess of 1,000 feet) is available. However, the Investigation recognises that due to the prevailing weather conditions at the time of failure (cloud base of 800 ft) such height was not available to the Pilot.
9. The Investigation is satisfied that directional control was lost approximately 30-35 seconds after the loss of the tail rotor, as a result of the IAS decaying below 60 kts.
10. The EI-SBM tail rotor drive-shaft failure is the first such occurrence recorded by the manufacturer, Agusta Westland.
11. The failure of the tail rotor drive-shaft was caused by a cleaning cloth, which had become wrapped around the shaft, causing cyclic fatigue and failure of the shaft.
12. The Investigation is satisfied that the cloth was originally left in the space between the No. 1 and No. 2 Hanger Assemblies, and did not migrate into this space from another location in the helicopter.
13. The Pilot advised the Investigation that he did not see the cleaning cloth on any occasion during which he was obliged to open the tail rotor drive-shaft cover prior to the initial flight of each day.
14. During the two post accident interviews conducted by the Investigation, the Pilot's accounts, as to whether the tail rotor drive-shaft cowling was opened or not, were at variance with each other. However, the Investigation recognises that during the first interview the Pilot was under the influence of significant pain killing medication.

FINAL REPORT

15. The Investigation was unable to definitively determine how, when and by whom the cloth was introduced into the drive-shaft area. However, as the maintenance organisation was solely responsible for the maintenance of the helicopter up to and including the 20th March 2008, the Investigation is of the opinion that the origin of the cleaning cloth was probably from the stocks of the maintenance organisation.
16. The presence of the cleaning cloth on the tail rotor drive-shaft area was most probably the result of systemic and human error.

(b) Cause

The accident was caused by fatigue and failure of the long tail rotor drive-shaft, which was induced by a cleaning cloth becoming wrapped around the shaft.

4. SAFETY RECOMMENDATION

It is recommended that:

1. The European Aviation Safety Agency (EASA) should strongly encourage all helicopter pilots to undergo Simulator Training, where available, on their initial Type Rating Course and, thereafter, to undertake Emergency Training when training for its revalidation. [\(SR 12 of 2009\)](#)
2. The Irish Aviation Authority issue a Notice to maintenance organisations with regard to the control of tools and materials used during maintenance, in accordance with the requirements of JAR 145. [\(SR 13 of 2009\)](#)

FINAL REPORT

Appendix A

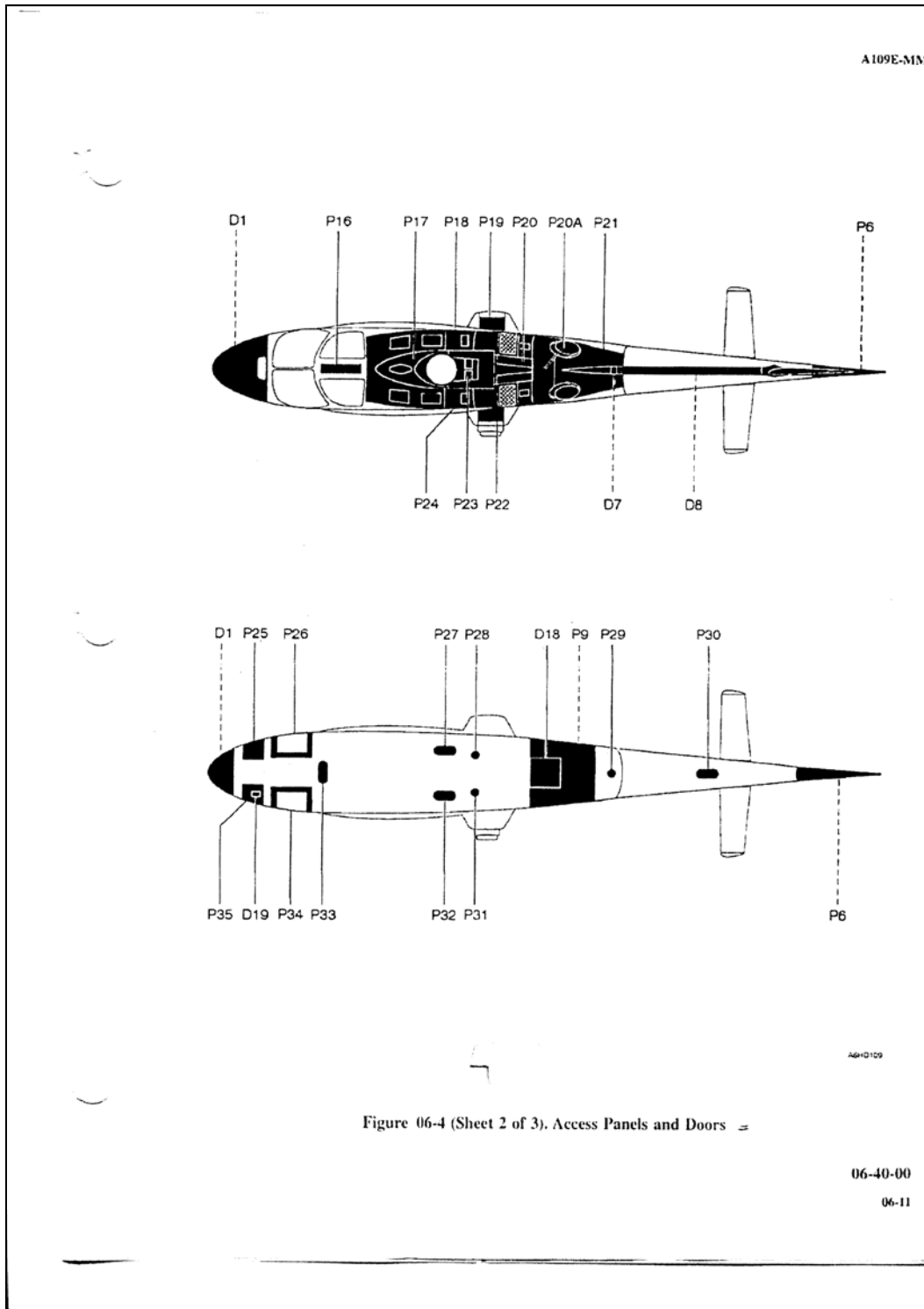

FINAL REPORT

Appendix B

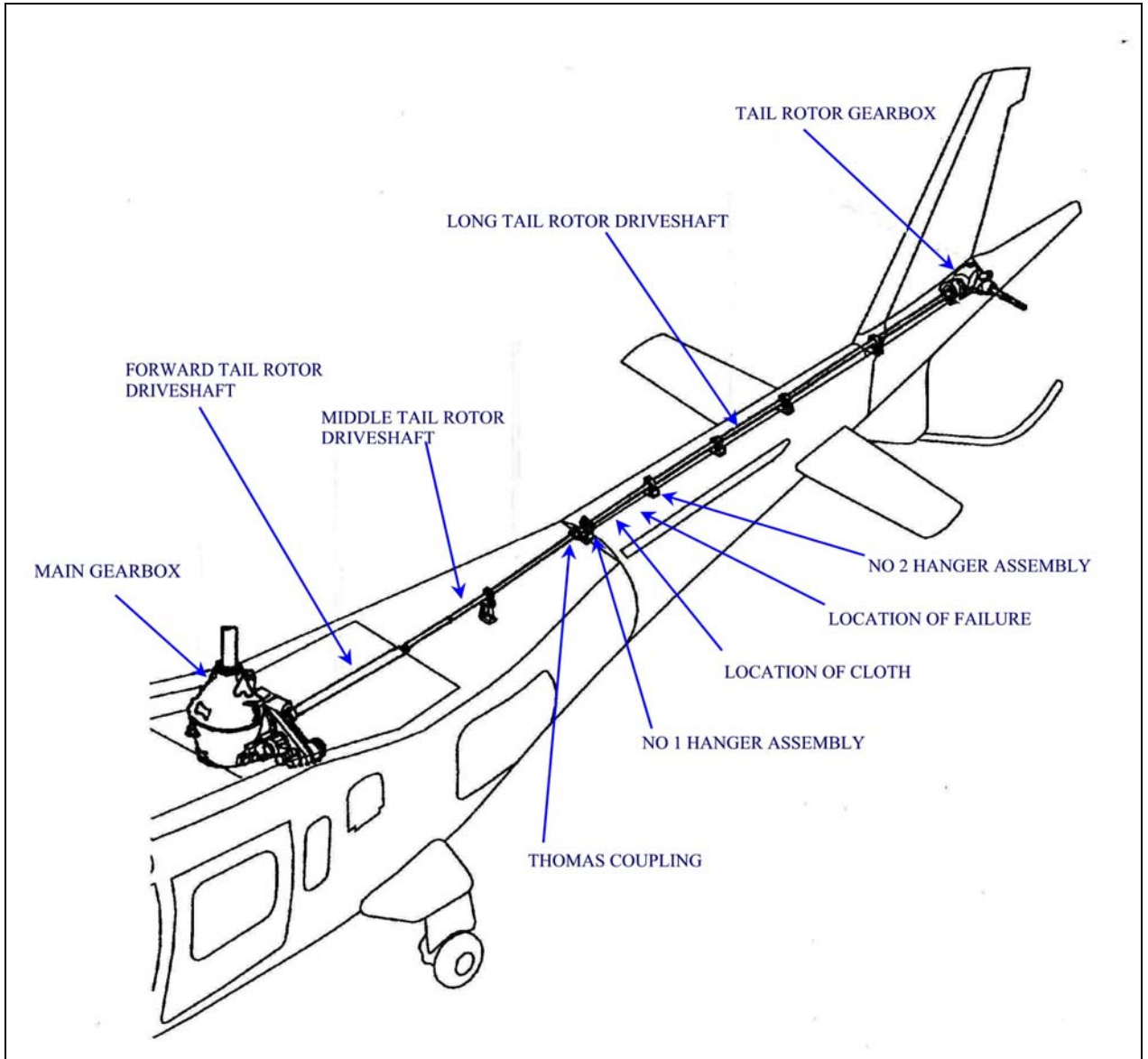

Figure B1

This figure shows the layout of the tail rotor drive system and its various components.

FINAL REPORT

Appendix C



Photo No. 1

This shows the location of the various fairings and the Aerodynamic Strake. This photo was taken after the helicopter was recovered to the AAIU facility and the distortion of the helicopter prevented the Thomas Coupling Cover and the Long Shaft Cover from closing completely.



Photo No. 2

This photograph (taken on another A109) shows the Thomas Coupling at the forward end of the Long Tail Rotor drive-shaft when the small Inspection Panel of the Middle Section fairing is in the open position. The rear end of the Middle Tail Rotor drive-shaft assembly is seen is the left of the opening. On the right, the front end of the Long Tail Rotor drive-shaft, and the No. 1 Hanger Assembly of the Long are also visible. The nuts, bolts and protruding bolt threads on the Coupling can be seen. No trace of material was found on these fittings. Elements of material were found on the bolts that secure the No.1 Hanger Assembly to the top of the tail boom.

FINAL REPORT

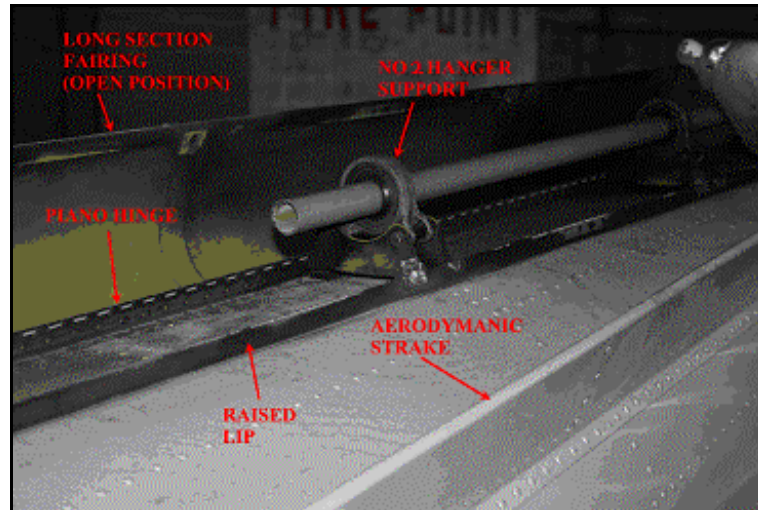

Photo No. 3

This shows the top of the tail-boom in the area of No. 2 Hanger Support showing the Long Section Fairing in the open position. The raised Lip and the Aerodynamic Strake can also be seen. It may be noted that in this picture the Long Shaft has been cut just forward of the No. 2 Hanger Support as part of the ongoing investigation.



Photo No. 4

Photograph taken at the accident site, showing the cloth, as found, wrapped around forward end of the Long Tail Rotor drive-shaft, and point of fracture of the Long Section. The splines leading into the forward Thomas Coupling can be seen on the left, just to the left of the No. 1 Hanger Assembly. To the right, the No. 2 Hanger Assembly can be seen.

FINAL REPORT



Photo No. 5

Photograph showing the cloth after it was removed from the Long Tail Rotor drive-shaft and unravelled by the Investigation. The ruler is 50 cm long.



Photo No. 6

This photograph shows the Piano Hinge of the Long Section Fairing. The light of a torch is seen through the gaps along the hinge line.

FINAL REPORT



Photo No. 7

This shows a similar view to the previous photograph, but with an altered camera setting so that the gaps can be seen more clearly.

FINAL REPORT

Appendix D

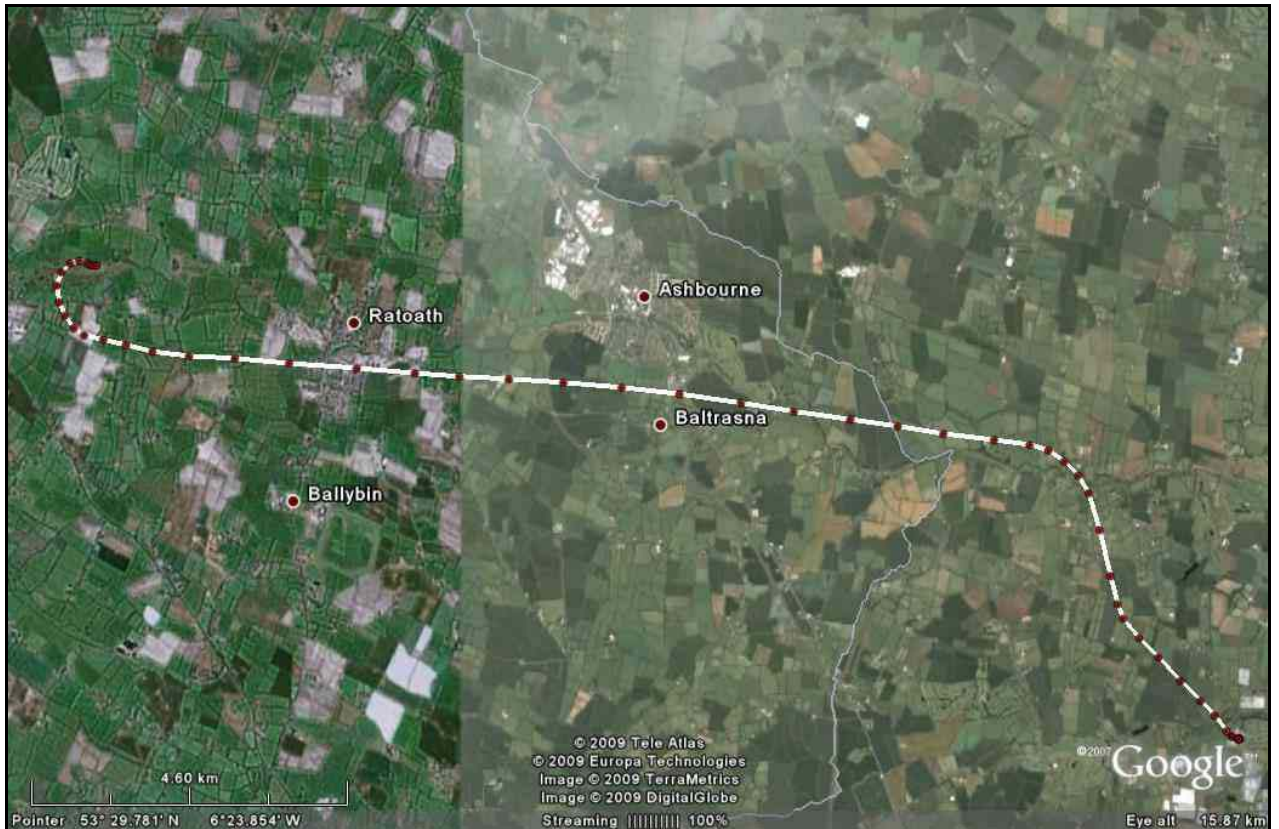

Figure D1

This shows the final flight of EI-SBM from Knocksedan to Dunshaughlin taken from the on-board GPS. The red dots are the recorded track points. The final turn to the right can be seen on the left of the figure. The right side of the figure is in a Google high-resolution area while the left side is low resolution. This is the reason for the tone difference.

FINAL REPORT



Figure D2

Reconstruction of last 54 seconds of flight. A constant wind of 270/22 was assumed. Aircraft ground speed and heading were resolved into component “airspeed” vectors parallel and perpendicular to 270. The components parallel to 270 were added, and the magnitude of the resultant of this addition and the perpendicular component was computed as an estimated airspeed experienced by the helicopter. Time calculations were performed to estimate the duration between TR loss and impact.

FINAL REPORT

Appendix E

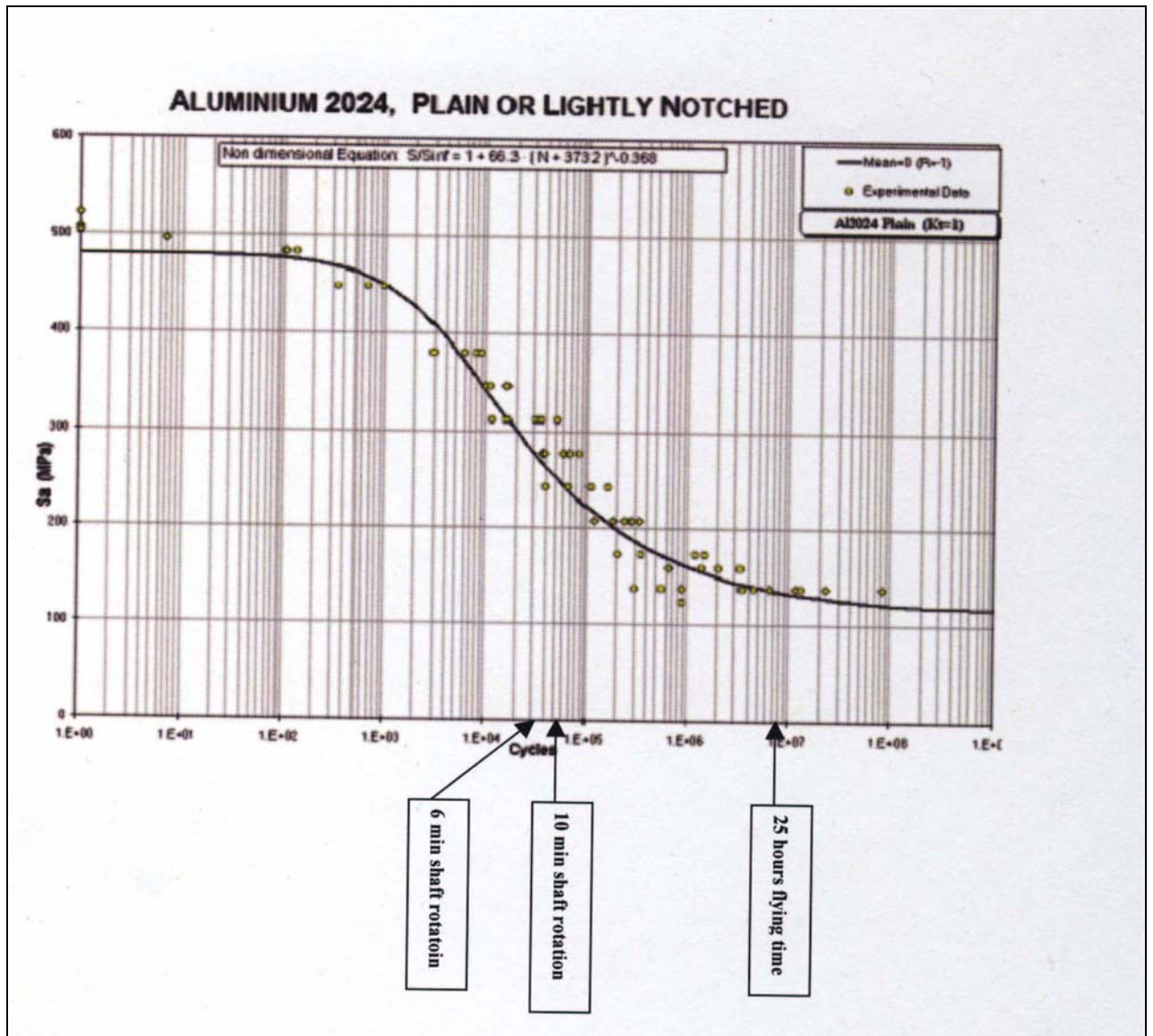

Figure E1

The stress versus cycles-to-failure data (S-N curve) for Aluminium Alloy 2024, based on data provided by Agusta Westland.

- END -